

**MR** MARC REALTY

30

NORTH MICHIGAN  
AVENUE

**CANDICE WELLS**

Leasing Agent

312.884.5452

[cwells@marcrealty.com](mailto:cwells@marcrealty.com)





# WELCOME TO THE MICHIGAN BOULEVARD BUILDING

**Property Type: Office**  
**Rate: \$30.00 - \$37.00 RSF/Gross**  
**Stories: 21**

A premier building, this prominent structure is a part of the famous Streetwall District that runs along Michigan Avenue. Featuring a beautiful white terra-cotta exterior with great views of Millennium Park and Lake Michigan, this offer is a one of a kind opportunity.







## **THE BEST LOCATION IN THE EAST LOOP**

Directly across from Millennium Park, within one block to Grant Park and The Art Institute. Bank of America, The Chicago Athletic Association, Cindy's Rooftop, Starbucks, The Gage, Park Grill and many more within a 1-block radius.

Ample parking is available at Millennium Park, Grant Park and nearby city garages. Within walking distance of public transportation (Loop Link, Buses, "L", Metra and DIVVY).

# MAP KEY



CTA STOP



PARKING GARAGE



TRAIN STATION



LANDMARK



BIKE LANE



5 MINUTE WALK RADIUS



'L' LINE

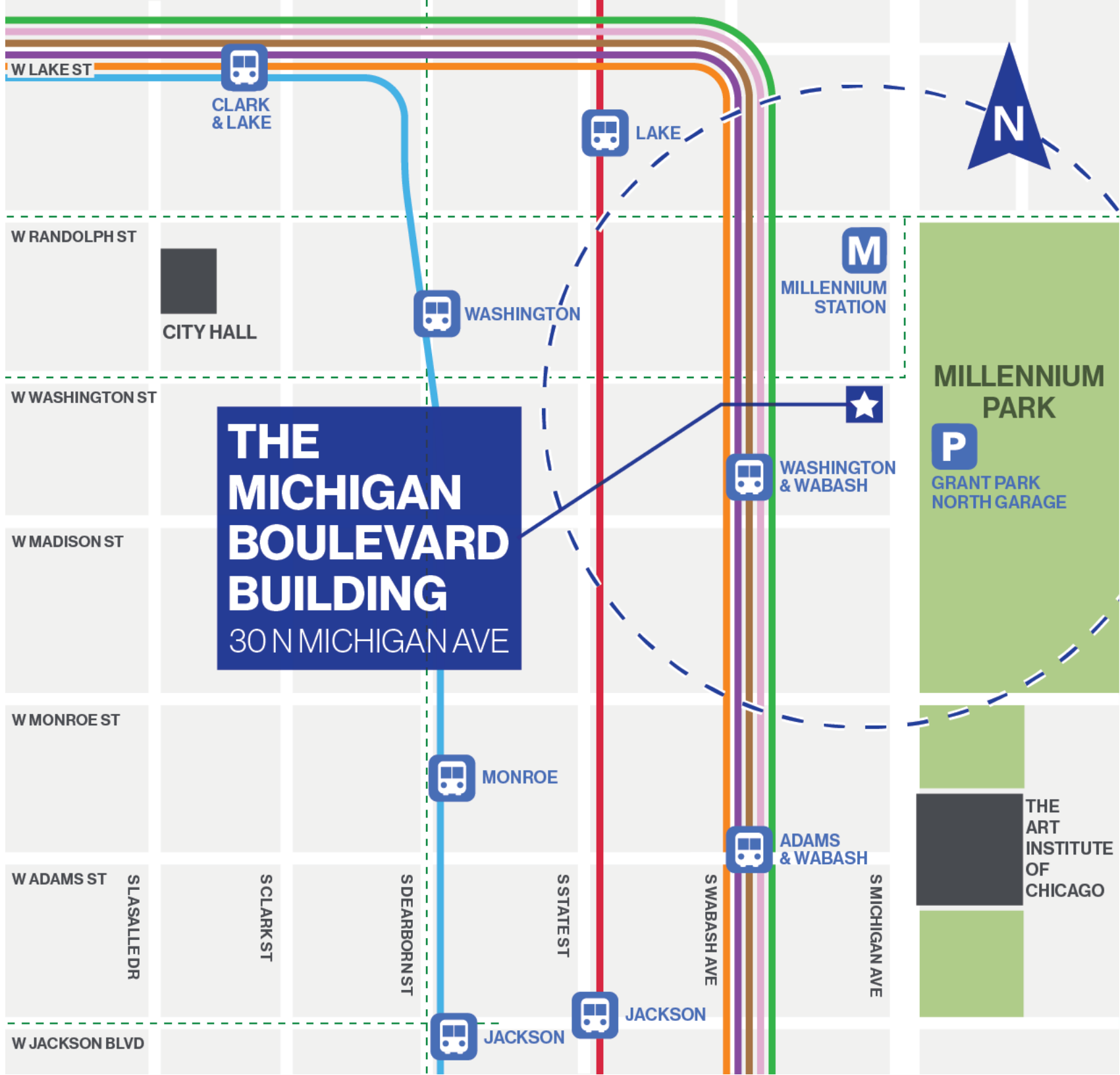

# 30

NORTH MICHIGAN  
AVENUE

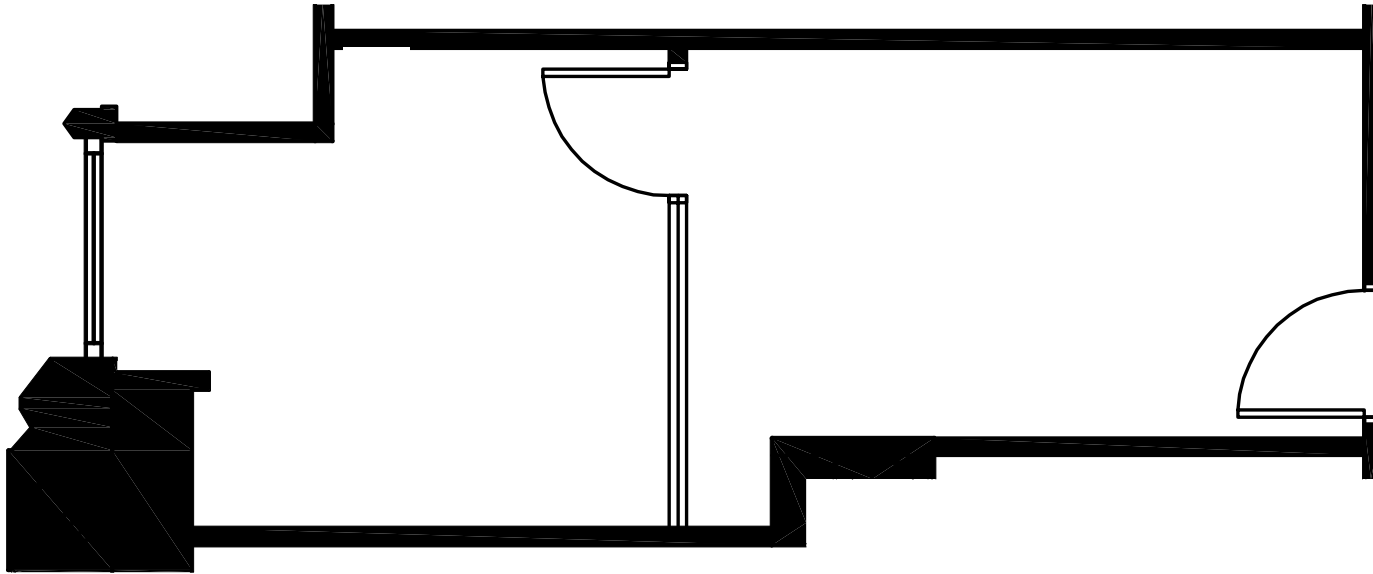
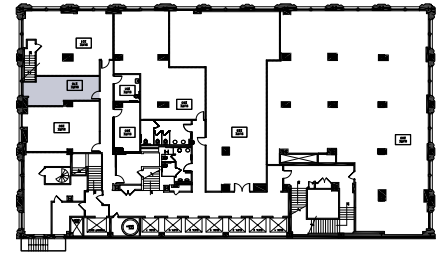

## SUITE 270

416 RSF

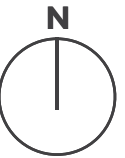

**CANDICE WELLS**

Leasing Agent  
312.884.5452 | [cwells@marcrealty.com](mailto:cwells@marcrealty.com)

55 E Jackson Blvd, Suite 500  
Chicago, IL 60604



Exceptional Value  
Remarkable Locations

# 30

NORTH MICHIGAN  
AVENUE

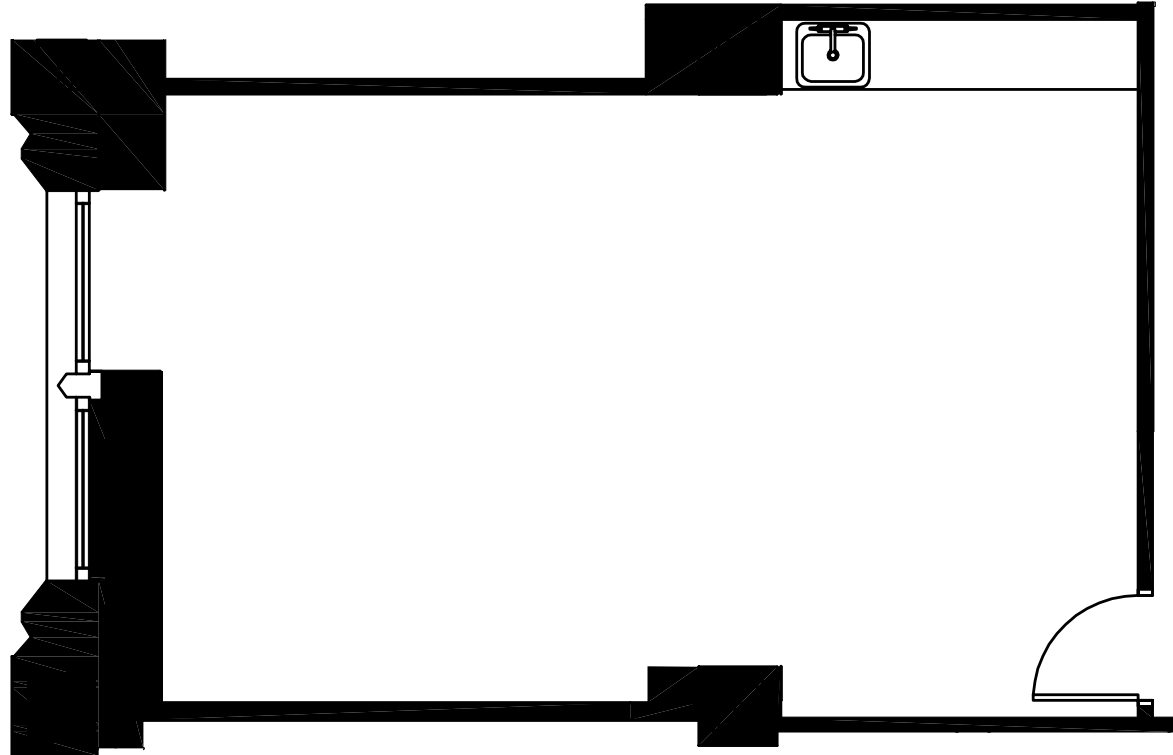
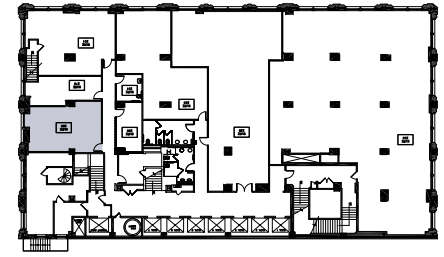

## SUITE 280

745 RSF

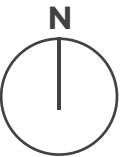

**CANDICE WELLS**

Leasing Agent  
312.884.5452 | [cwells@marcrealty.com](mailto:cwells@marcrealty.com)

55 E Jackson Blvd, Suite 500  
Chicago, IL 60604



Exceptional Value  
Remarkable Locations



# 30

NORTH MICHIGAN  
AVENUE

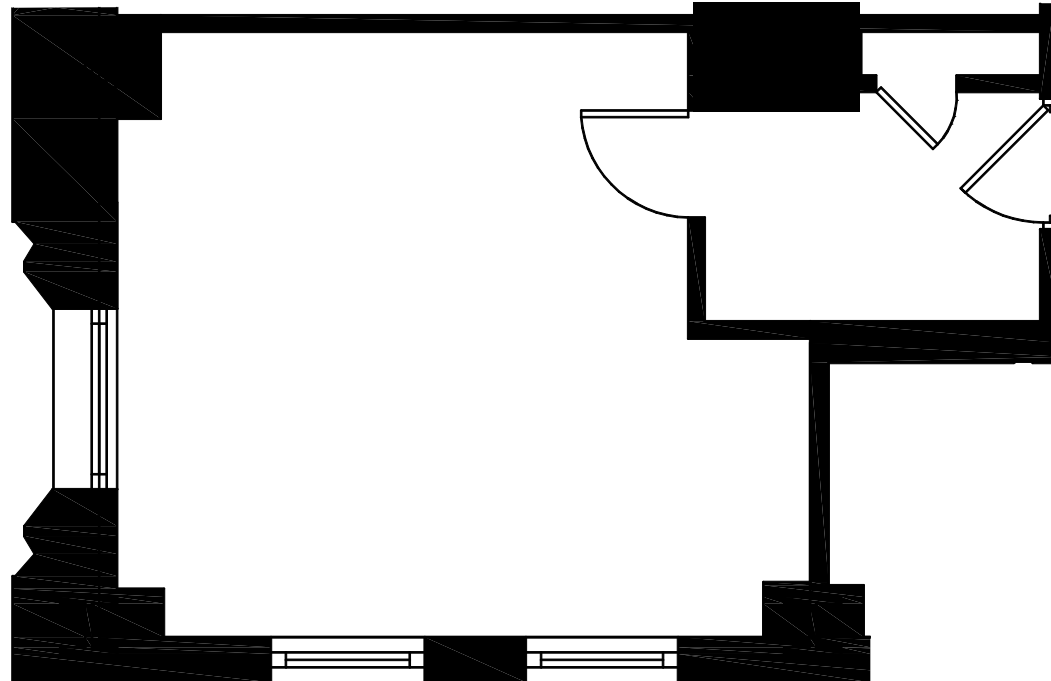
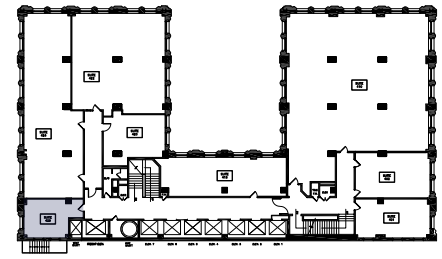

## SUITE 429

387 RSF

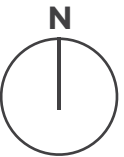

### CANDICE WELLS

Leasing Agent  
312.884.5452 | [cwells@marcrealty.com](mailto:cwells@marcrealty.com)

55 E Jackson Blvd, Suite 500  
Chicago, IL 60604



Exceptional Value  
Remarkable Locations

# 30

NORTH MICHIGAN  
AVENUE

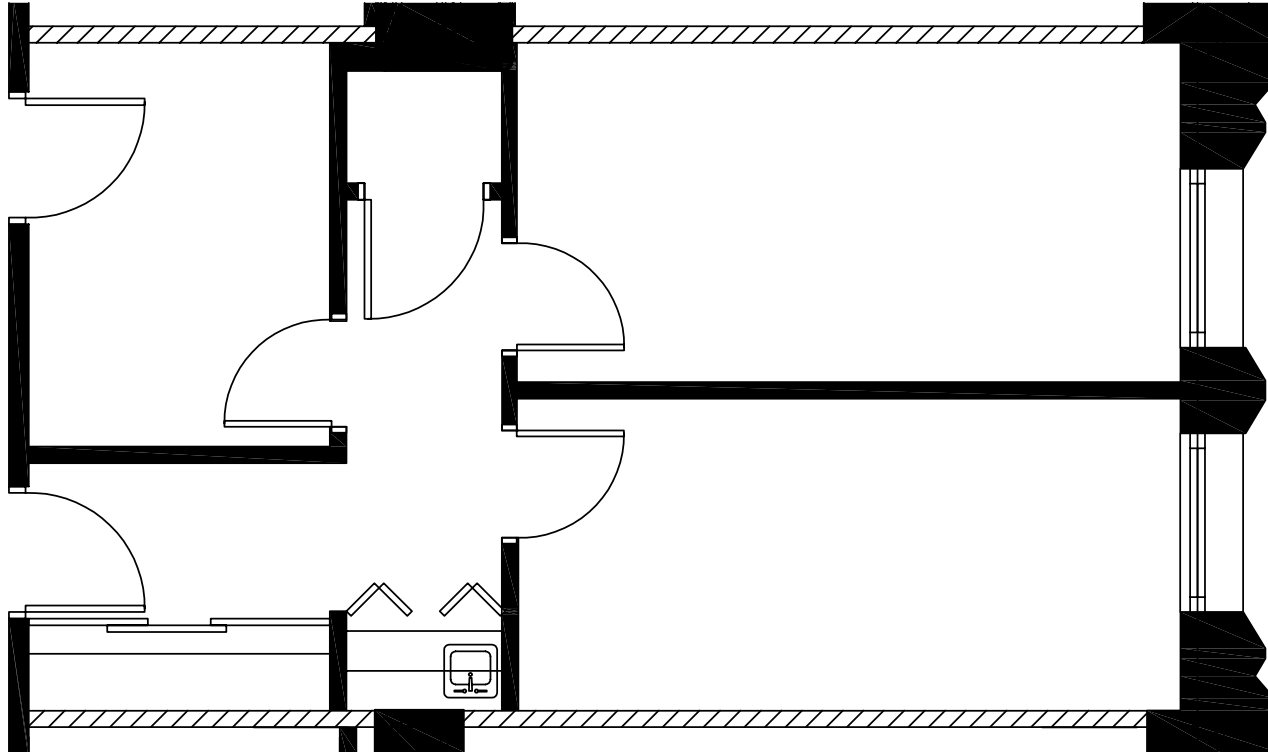
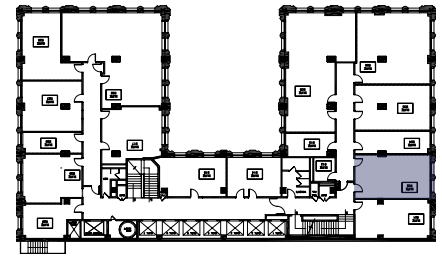

## SUITE 502

650 RSF

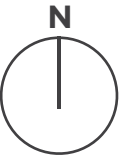

**CANDICE WELLS**

Leasing Agent  
312.884.5452 | cwells@marcrealty.com

55 E Jackson Blvd, Suite 500  
Chicago, IL 60604



Exceptional Value  
Remarkable Locations



# 30

NORTH MICHIGAN  
AVENUE

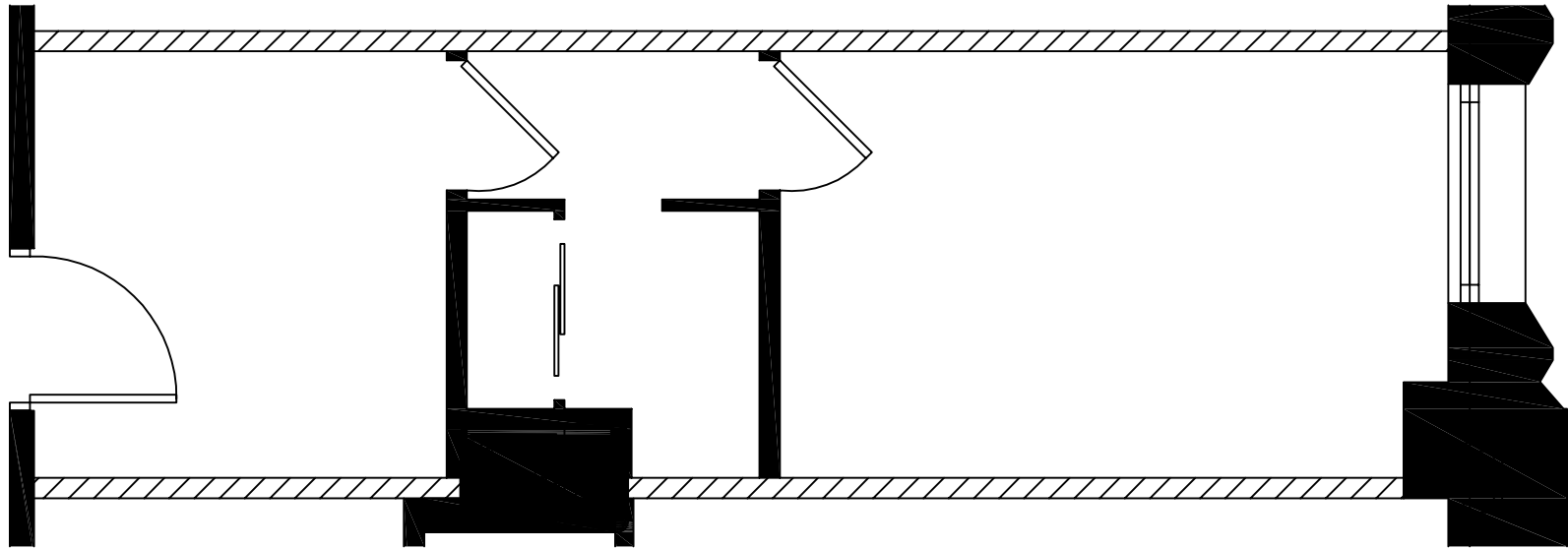
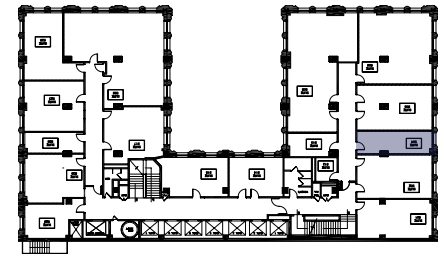

## SUITE 504

330 RSF



**CANDICE WELLS**

Leasing Agent  
312.884.5452 | [cwells@marcrealty.com](mailto:cwells@marcrealty.com)

55 E Jackson Blvd, Suite 500  
Chicago, IL 60604



Exceptional Value  
Remarkable Locations

# 30

NORTH MICHIGAN  
AVENUE

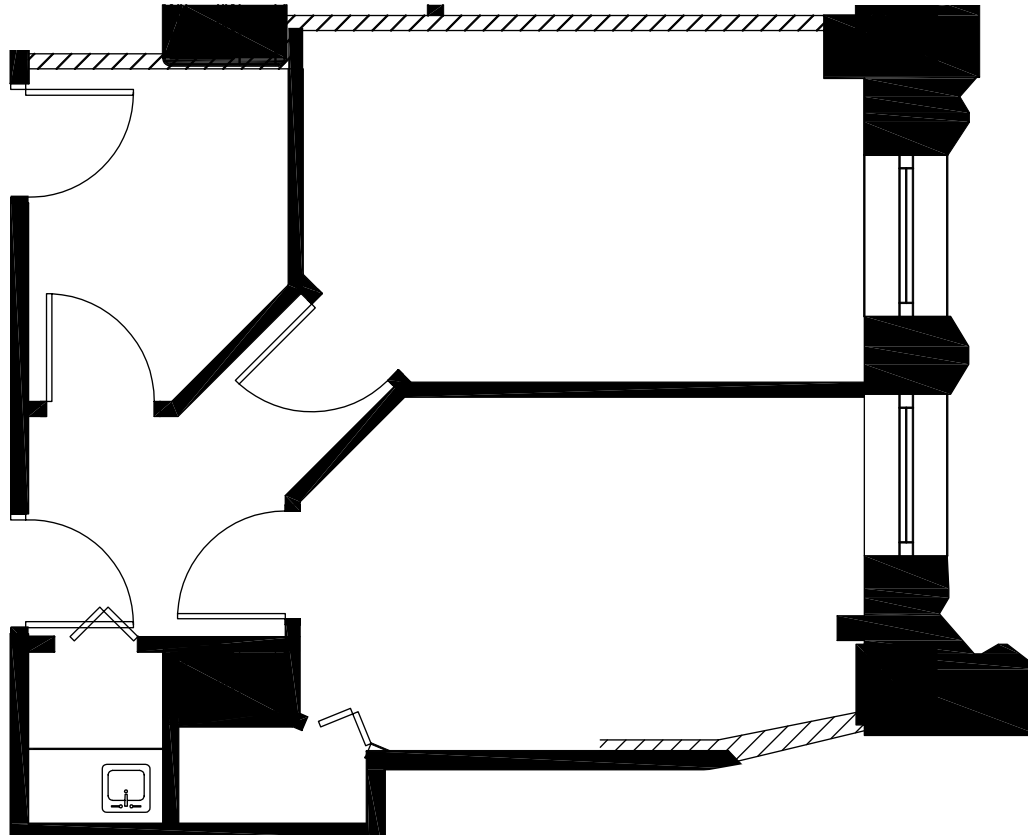
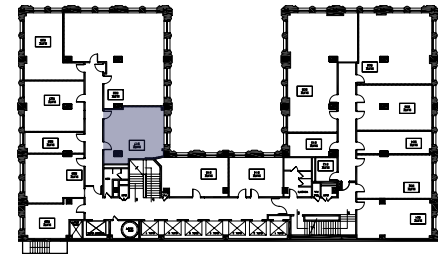

## SUITE 517

665 RSF

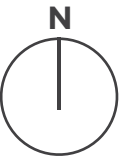

### CANDICE WELLS

Leasing Agent  
312.884.5452 | [cwells@marcrealty.com](mailto:cwells@marcrealty.com)

55 E Jackson Blvd, Suite 500  
Chicago, IL 60604



Exceptional Value  
Remarkable Locations



# 30

NORTH MICHIGAN  
AVENUE

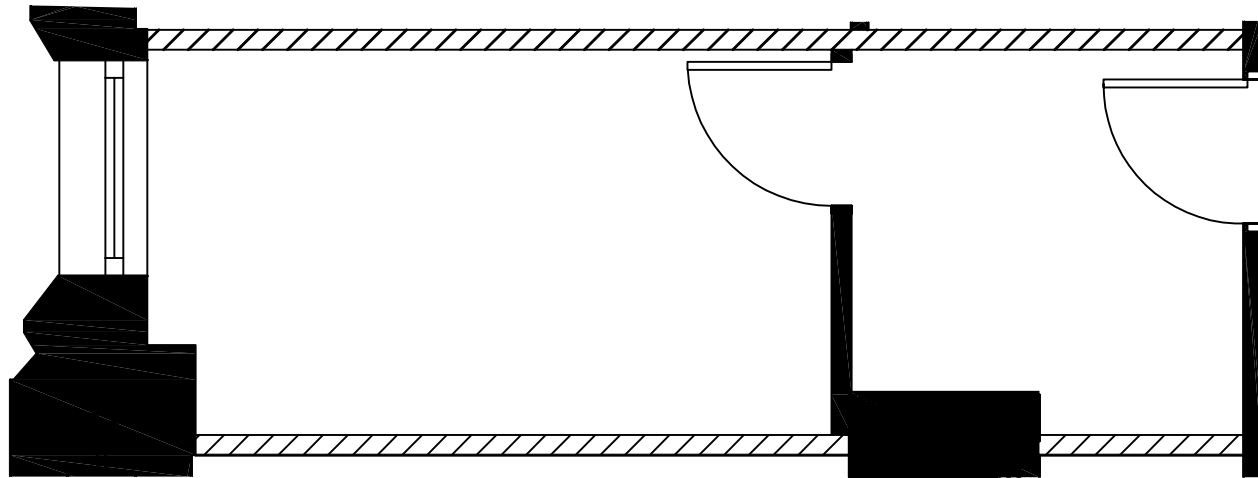
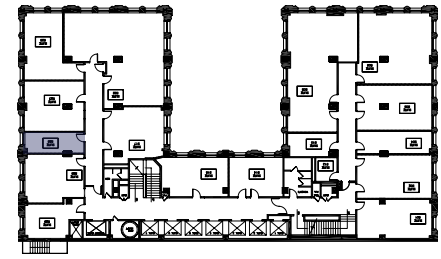

## SUITE 526

287 RSF

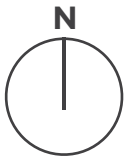

### CANDICE WELLS

Leasing Agent  
312.884.5452 | cwells@marcrealty.com

55 E Jackson Blvd, Suite 500  
Chicago, IL 60604



Exceptional Value  
Remarkable Locations

# 30

NORTH MICHIGAN  
AVENUE

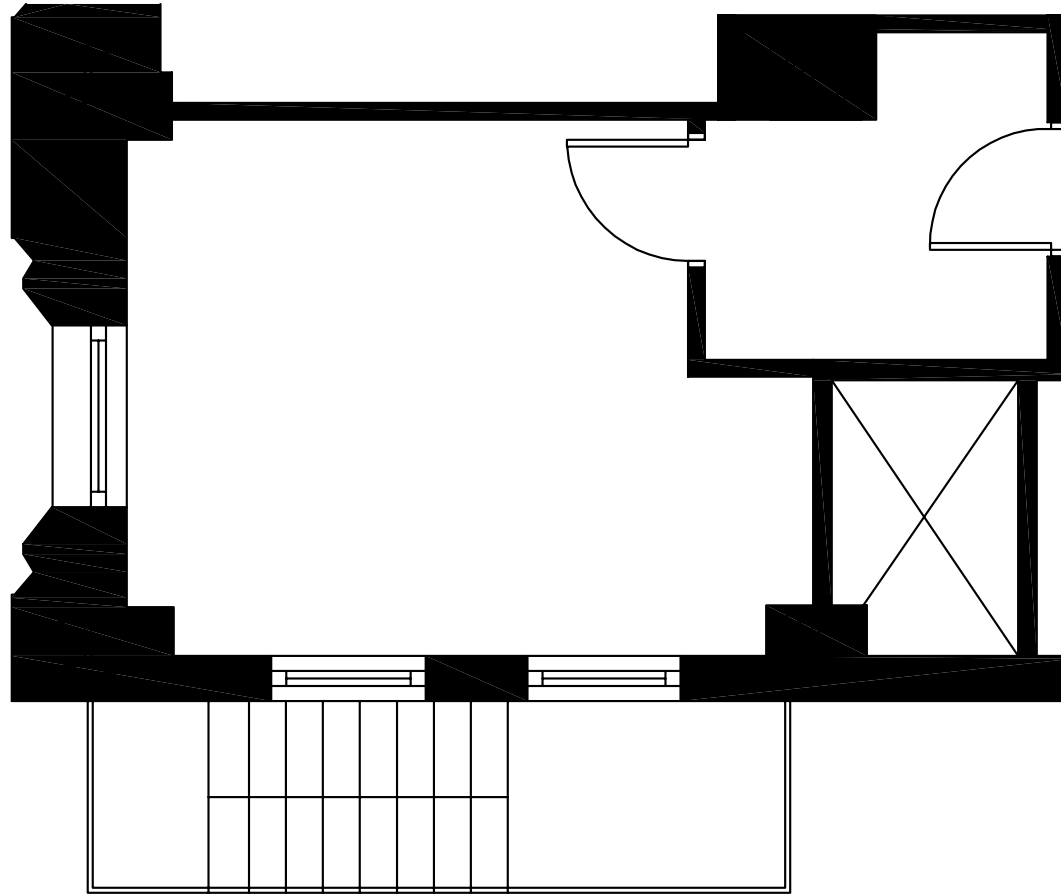
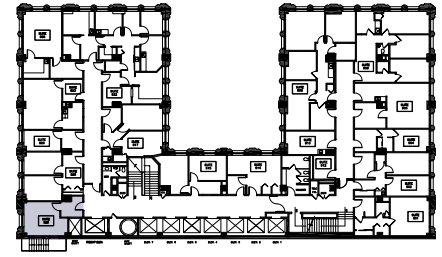

## SUITE 529

380 RSF

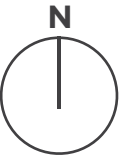

### CANDICE WELLS

Leasing Agent  
312.884.5452 | [cwells@marcrealty.com](mailto:cwells@marcrealty.com)

55 E Jackson Blvd, Suite 500  
Chicago, IL 60604



Exceptional Value  
Remarkable Locations



# 30

NORTH MICHIGAN  
AVENUE

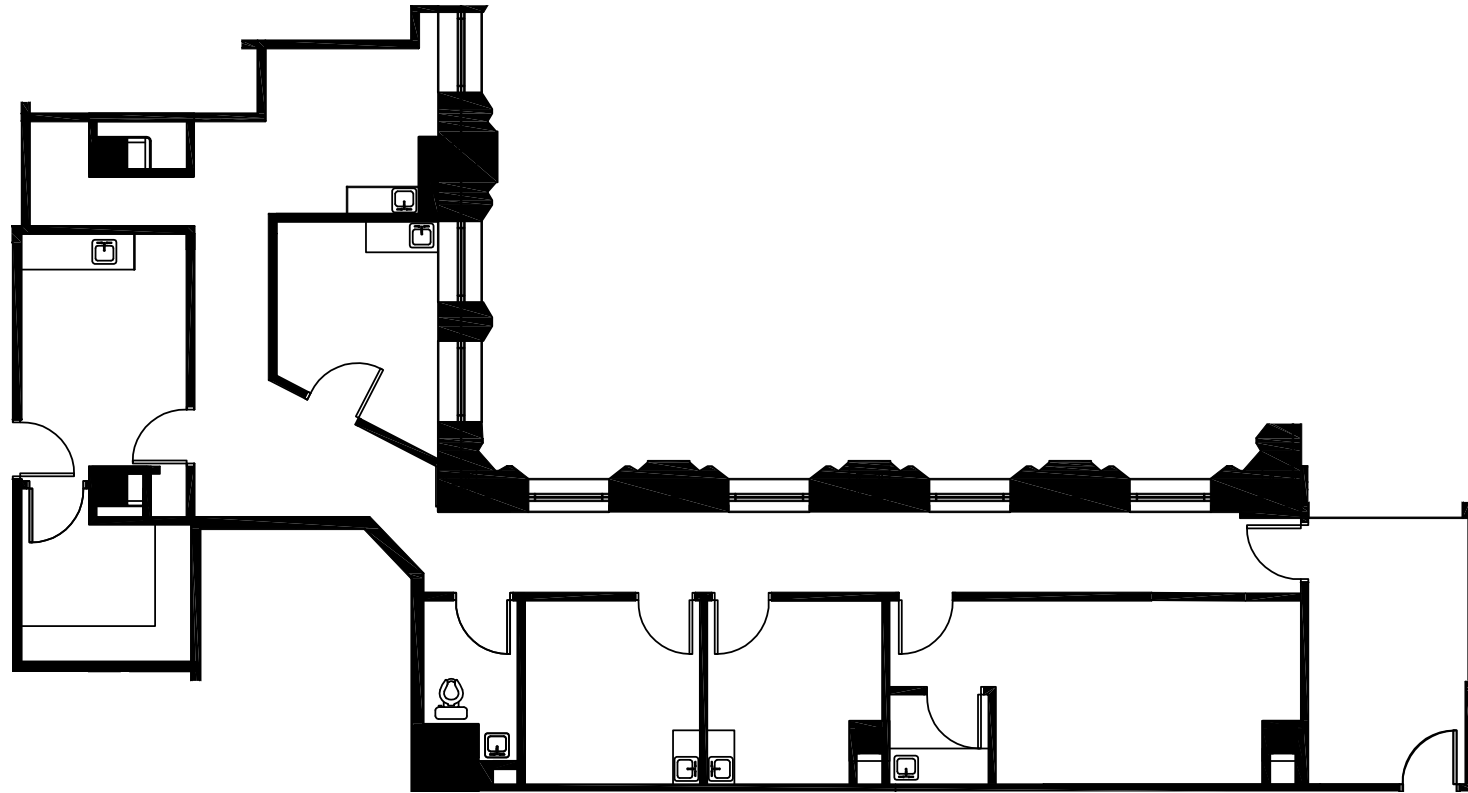
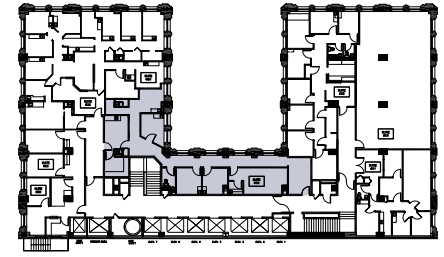

## SUITE 600

1,931 RSF



**CANDICE WELLS**

Leasing Agent  
312.884.5452 | [cwells@marcrealty.com](mailto:cwells@marcrealty.com)

55 E Jackson Blvd, Suite 500  
Chicago, IL 60604



Exceptional Value  
Remarkable Locations

# 30

NORTH MICHIGAN  
AVENUE

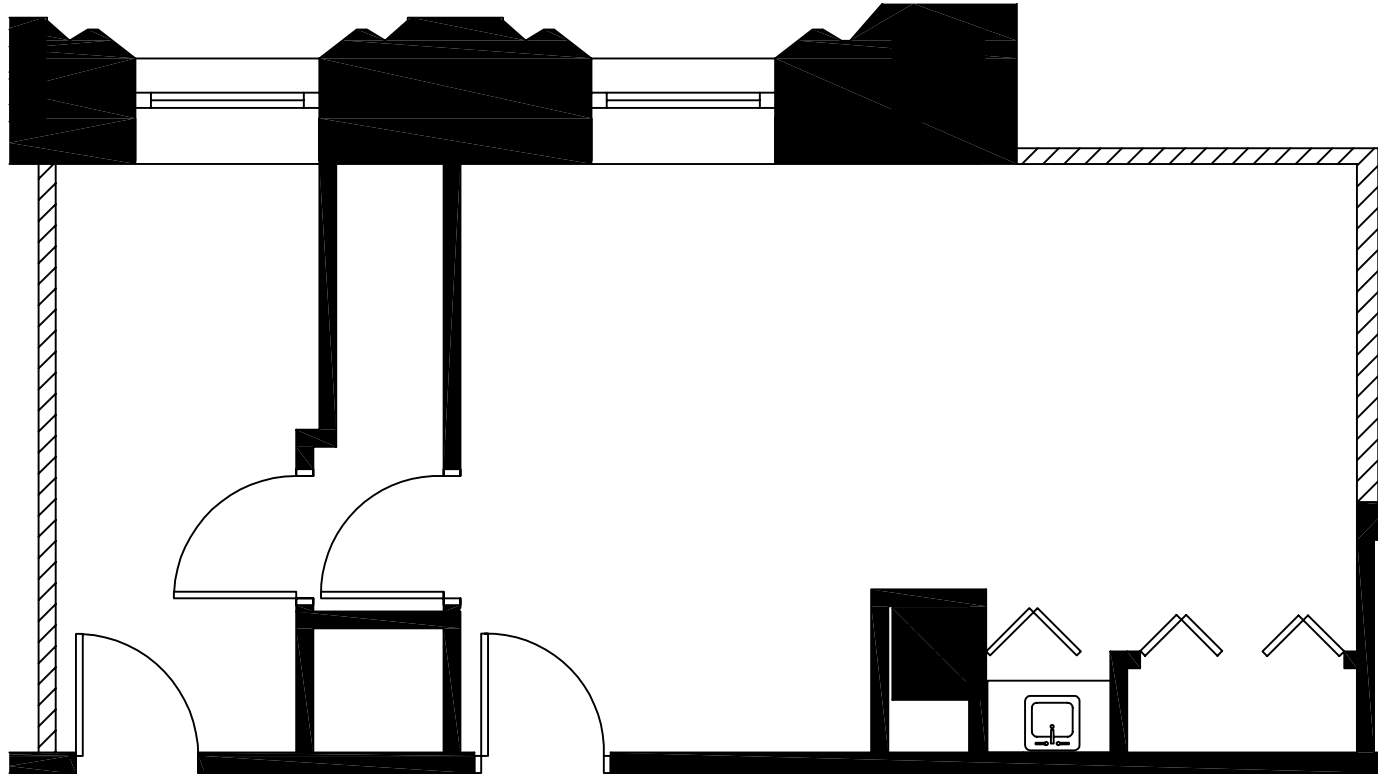
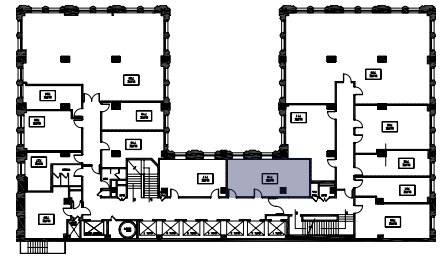

## SUITE 715

536 RSF

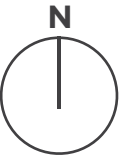

**CANDICE WELLS**

Leasing Agent  
312.884.5452 | cwells@marcrealty.com

55 E Jackson Blvd, Suite 500  
Chicago, IL 60604



Exceptional Value  
Remarkable Locations



# 30

NORTH MICHIGAN  
AVENUE

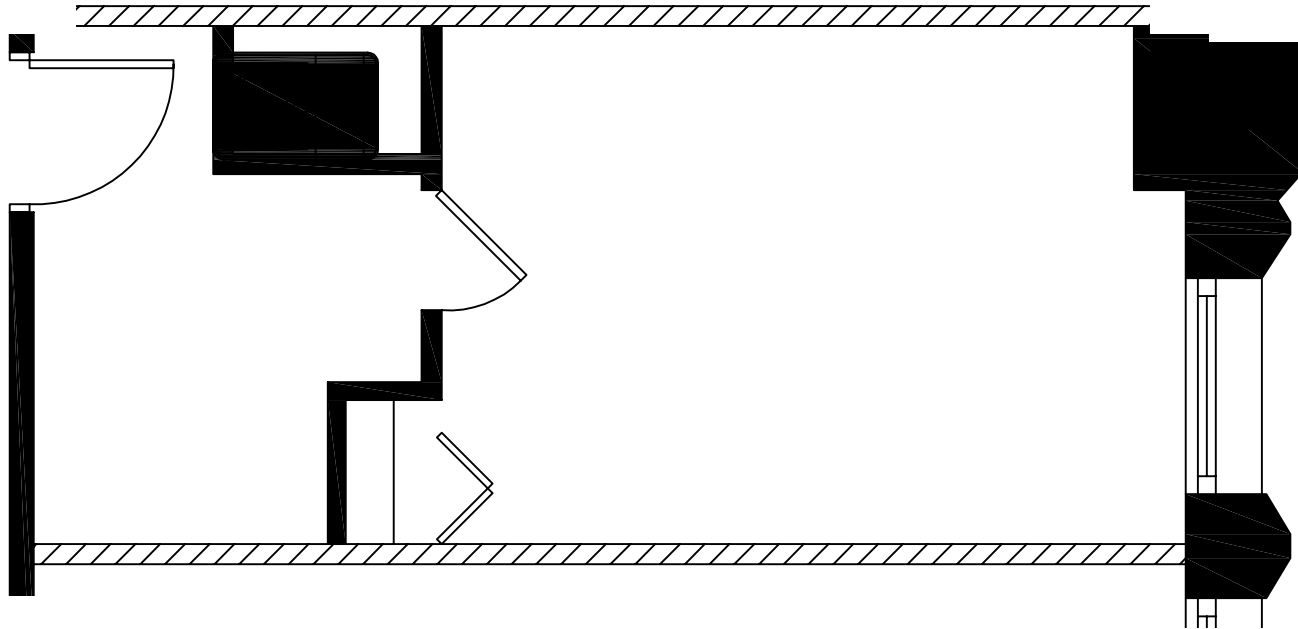
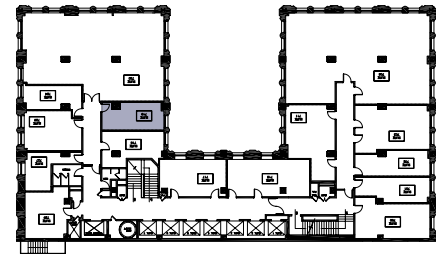

## SUITE 719

323 RSF



**CANDICE WELLS**

Leasing Agent  
312.884.5452 | [cwells@marcrealty.com](mailto:cwells@marcrealty.com)

55 E Jackson Blvd, Suite 500  
Chicago, IL 60604



Exceptional Value  
Remarkable Locations

# 30

NORTH MICHIGAN  
AVENUE

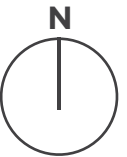
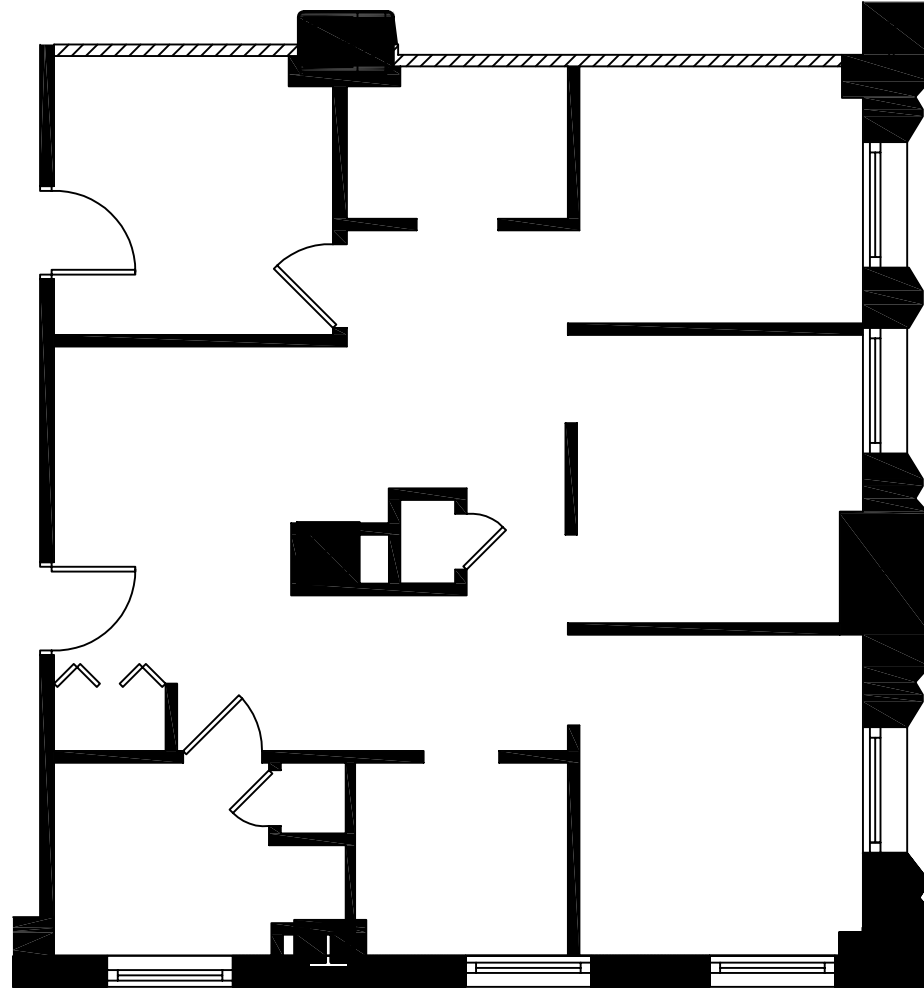
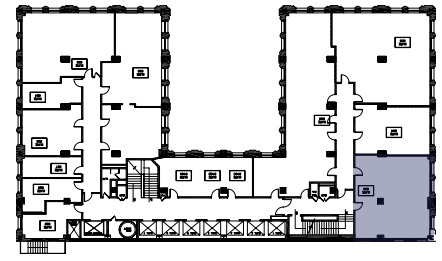

## SUITE 800

1,166 RSF

**CANDICE WELLS**

Leasing Agent  
312.884.5452 | [cwells@marcrealty.com](mailto:cwells@marcrealty.com)

55 E Jackson Blvd, Suite 500  
Chicago, IL 60604



Exceptional Value  
Remarkable Locations

# 30

NORTH MICHIGAN  
AVENUE

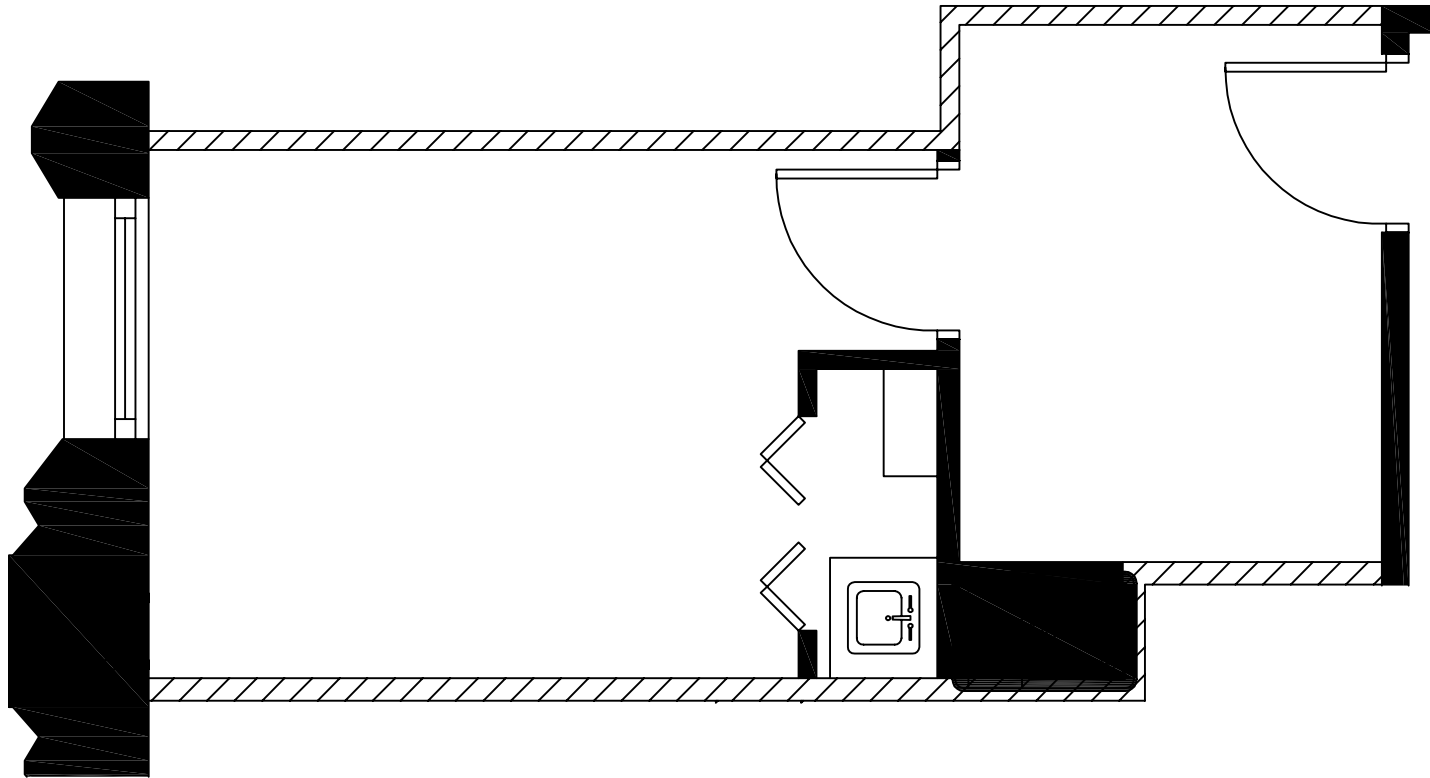
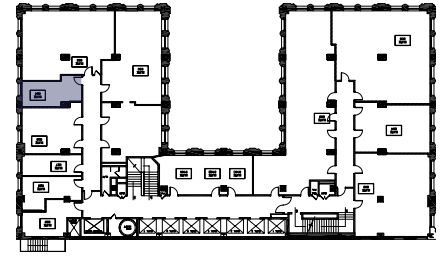

## SUITE 824

302 RSF

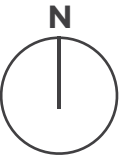

**CANDICE WELLS**

Leasing Agent  
312.884.5452 | [cwells@marcrealty.com](mailto:cwells@marcrealty.com)

55 E Jackson Blvd, Suite 500  
Chicago, IL 60604



Exceptional Value  
Remarkable Locations

# 30

NORTH MICHIGAN  
AVENUE

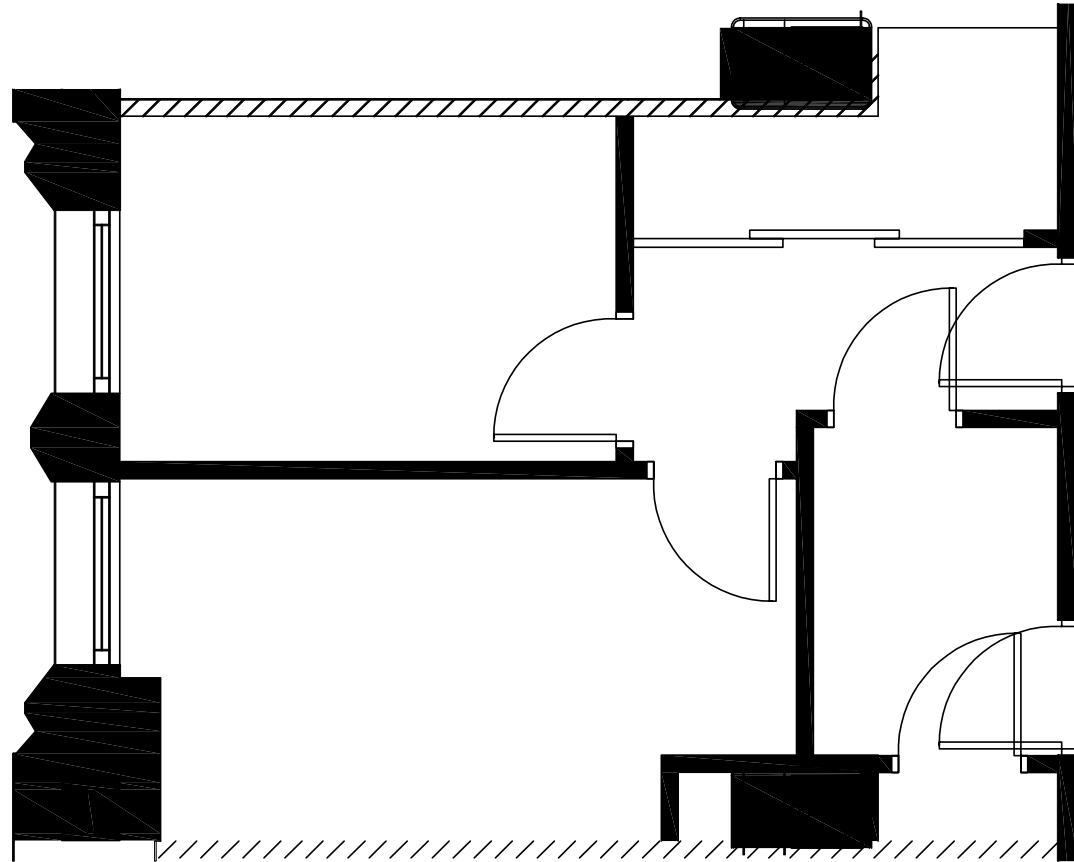
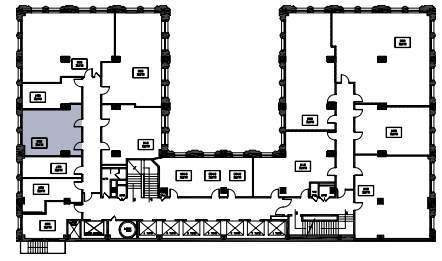

## SUITE 826

608 RSF

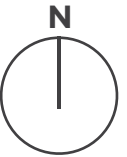

**CANDICE WELLS**

Leasing Agent  
312.884.5452 | [cwells@marcrealty.com](mailto:cwells@marcrealty.com)

55 E Jackson Blvd, Suite 500  
Chicago, IL 60604



Exceptional Value  
Remarkable Locations



# 30

NORTH MICHIGAN  
AVENUE

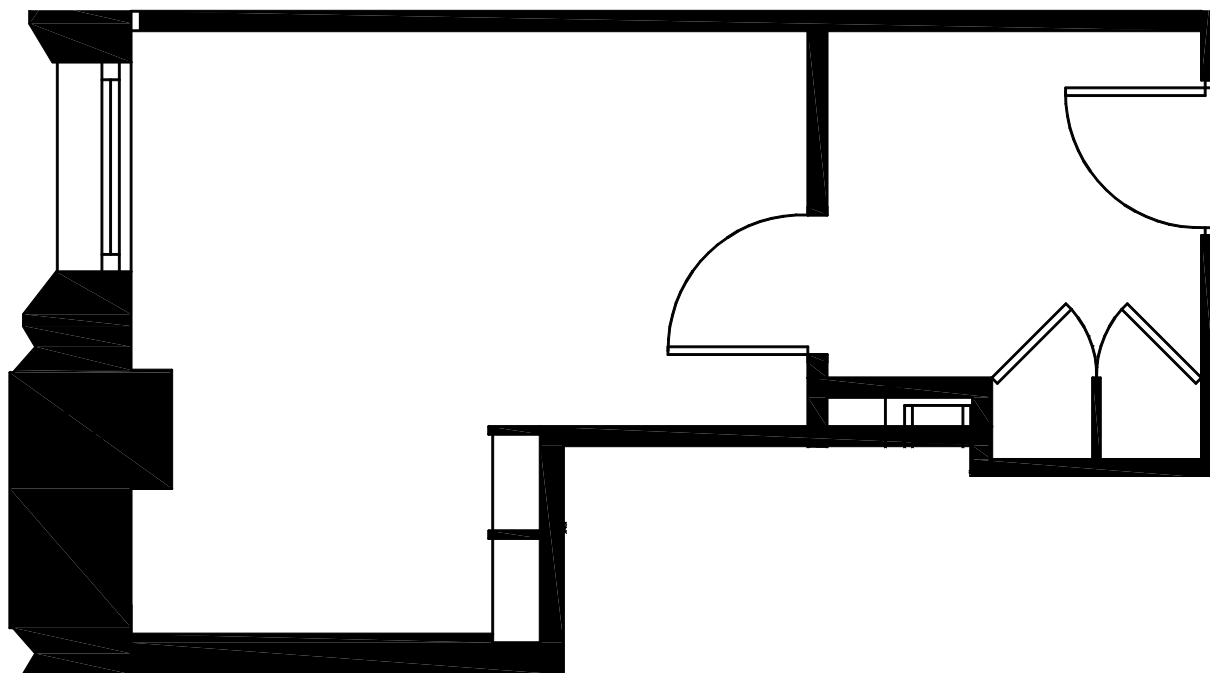
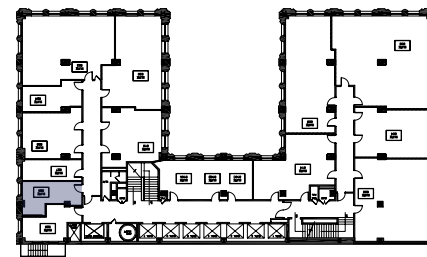

## SUITE 828

425 RSF



**CANDICE WELLS**

Leasing Agent  
312.884.5452 | [cwells@marcrealty.com](mailto:cwells@marcrealty.com)

55 E Jackson Blvd, Suite 500  
Chicago, IL 60604



Exceptional Value  
Remarkable Locations

# 30

NORTH MICHIGAN  
AVENUE

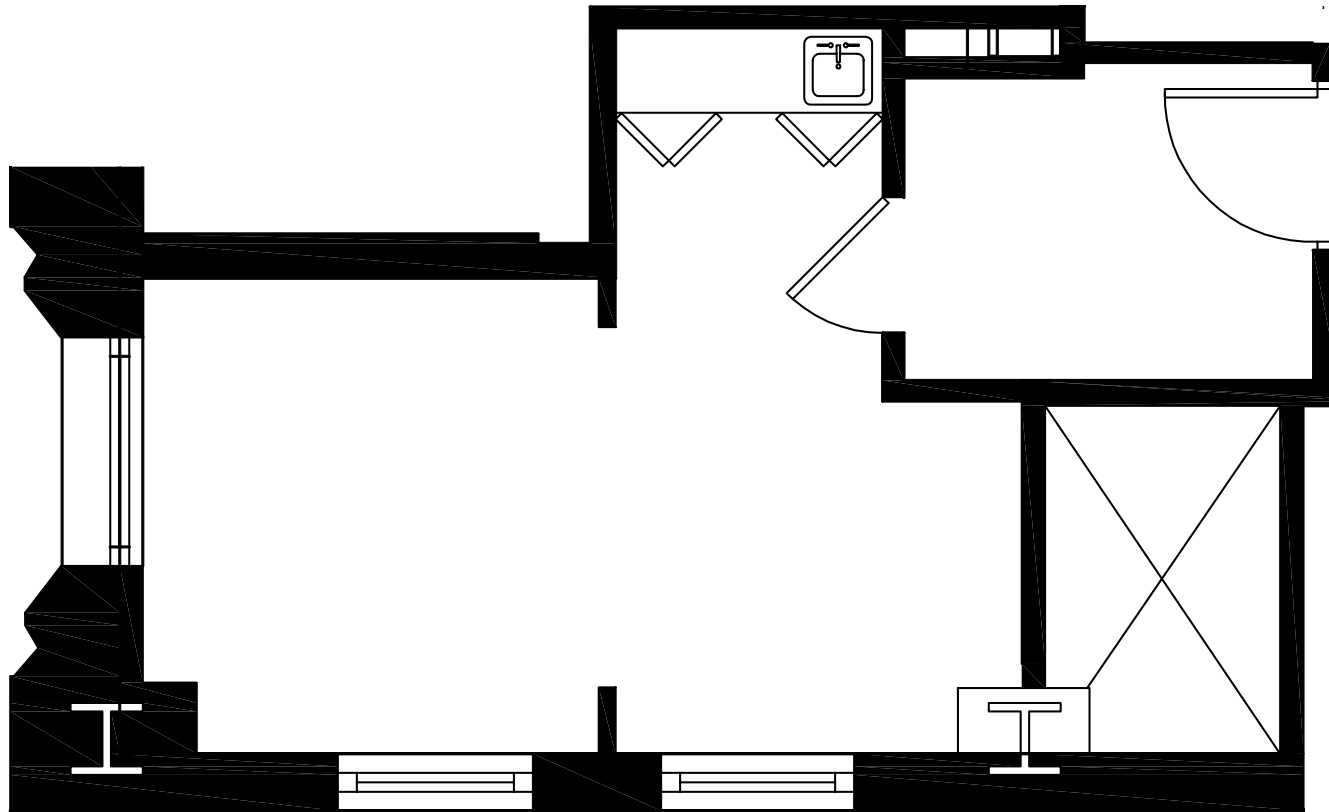
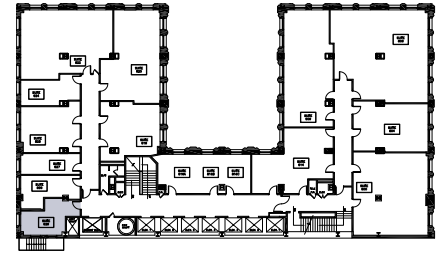

## SUITE 829

319 RSF

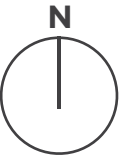

**CANDICE WELLS**

Leasing Agent  
312.884.5452 | [cwells@marcrealty.com](mailto:cwells@marcrealty.com)

55 E Jackson Blvd, Suite 500  
Chicago, IL 60604



Exceptional Value  
Remarkable Locations

# 30

NORTH MICHIGAN  
AVENUE

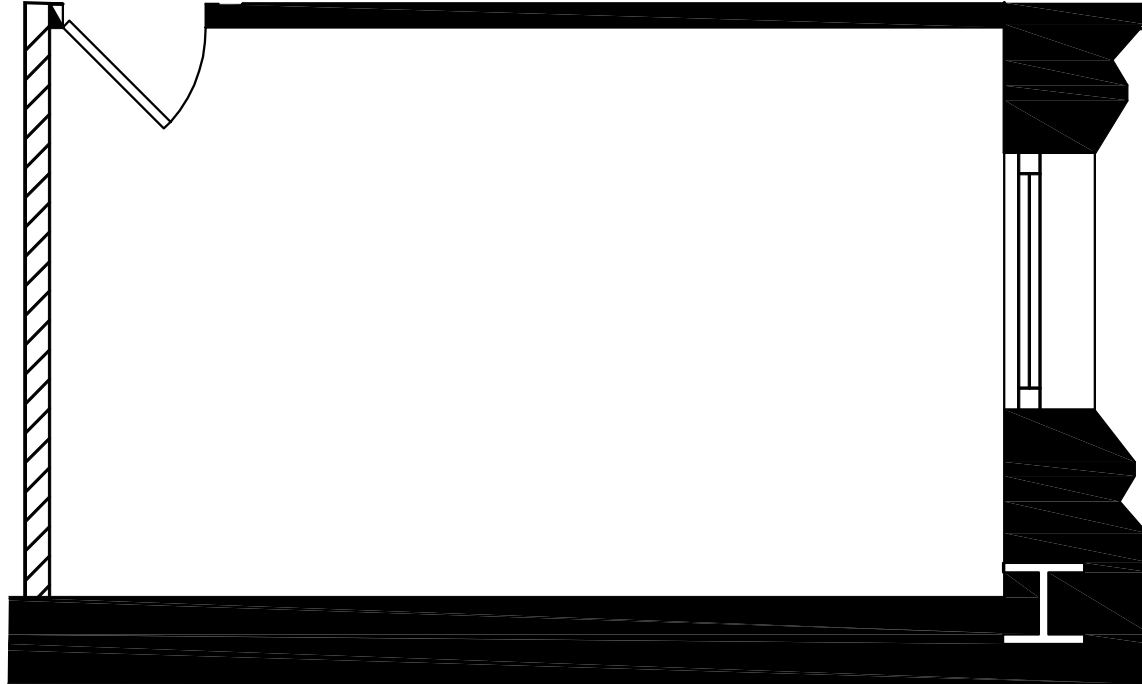
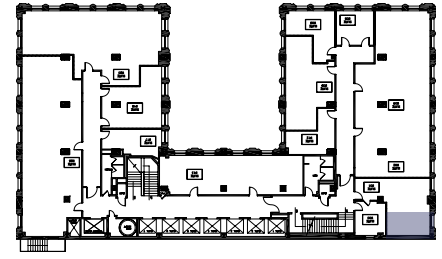

## SUITE 901B

295 RSF

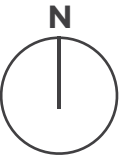

**CANDICE WELLS**

Leasing Agent  
312.884.5452 | [cwells@marcrealty.com](mailto:cwells@marcrealty.com)

55 E Jackson Blvd, Suite 500  
Chicago, IL 60604



Exceptional Value  
Remarkable Locations

# 30

NORTH MICHIGAN  
AVENUE

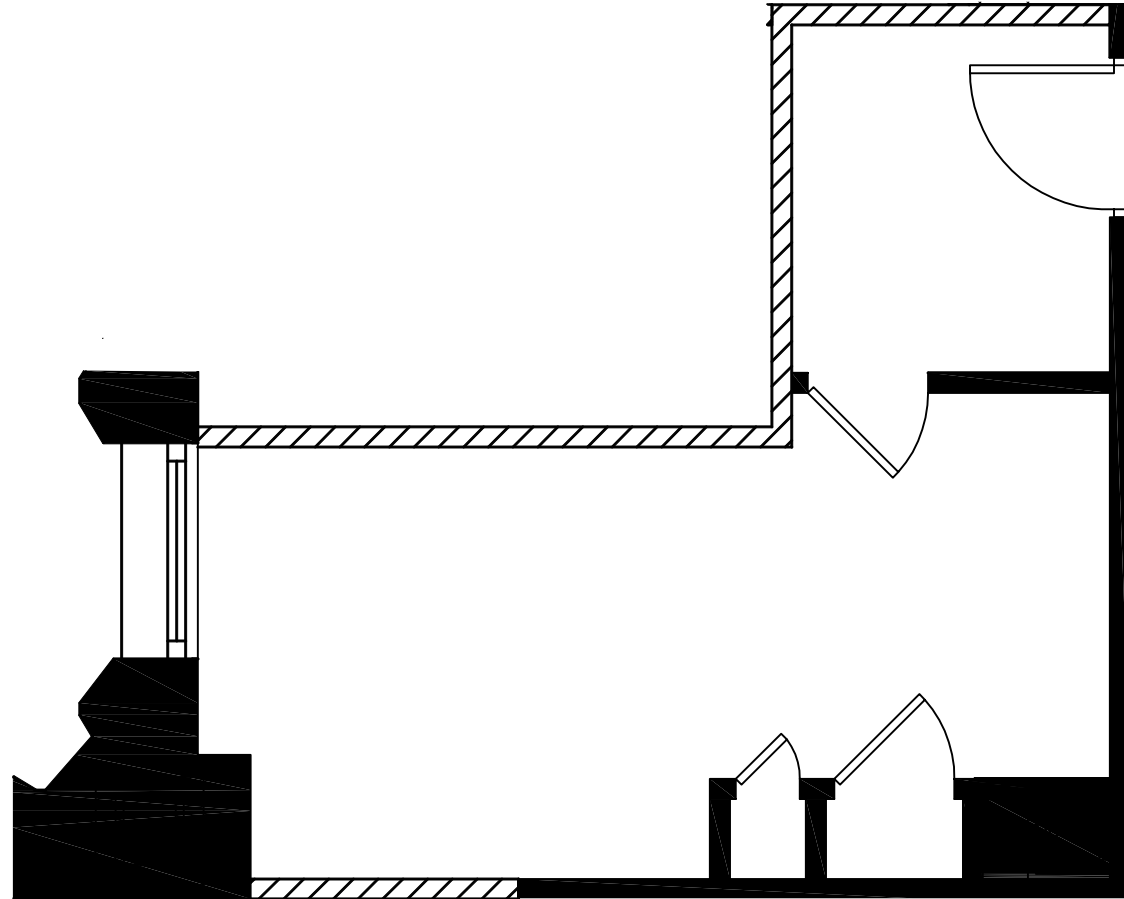
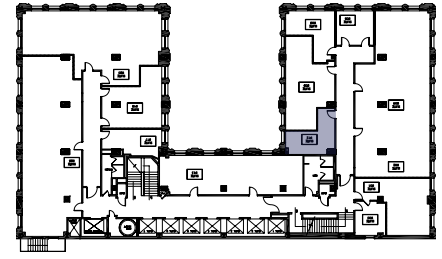

## SUITE 912

289 RSF

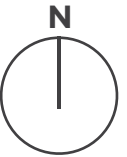

**CANDICE WELLS**

Leasing Agent  
312.884.5452 | cwells@marcrealty.com

55 E Jackson Blvd, Suite 500  
Chicago, IL 60604



Exceptional Value  
Remarkable Locations



# 30

NORTH MICHIGAN  
AVENUE

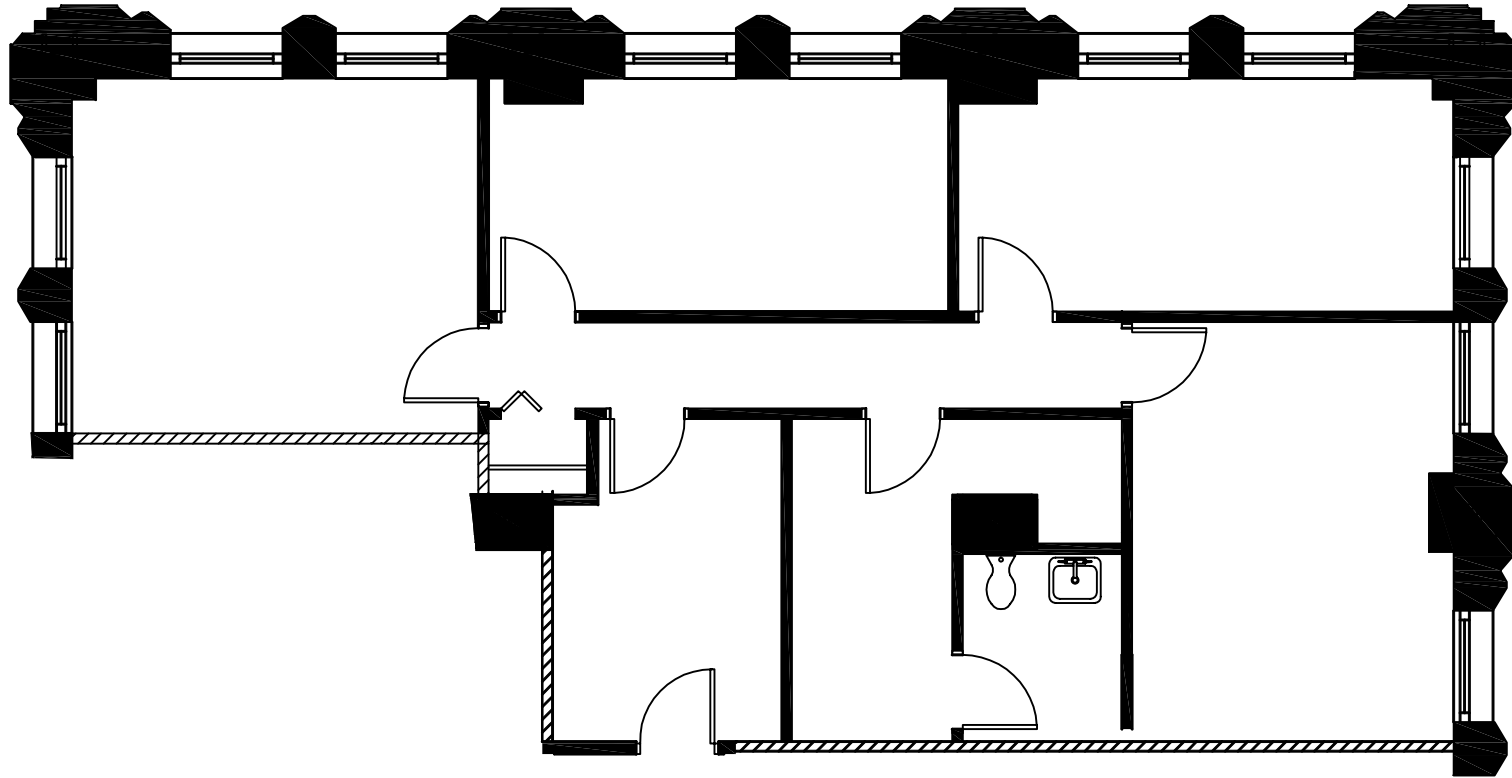
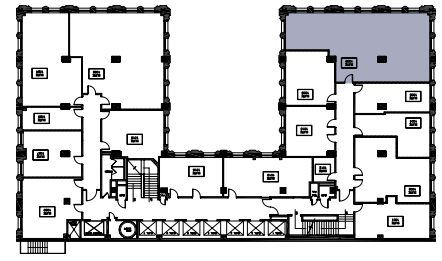

## SUITE 1008

1,580RSF



**CANDICE WELLS**

Leasing Agent  
312.884.5452 | cwells@marcrealty.com

55 E Jackson Blvd, Suite 500  
Chicago, IL 60604



Exceptional Value  
Remarkable Locations

# 30

NORTH MICHIGAN  
AVENUE

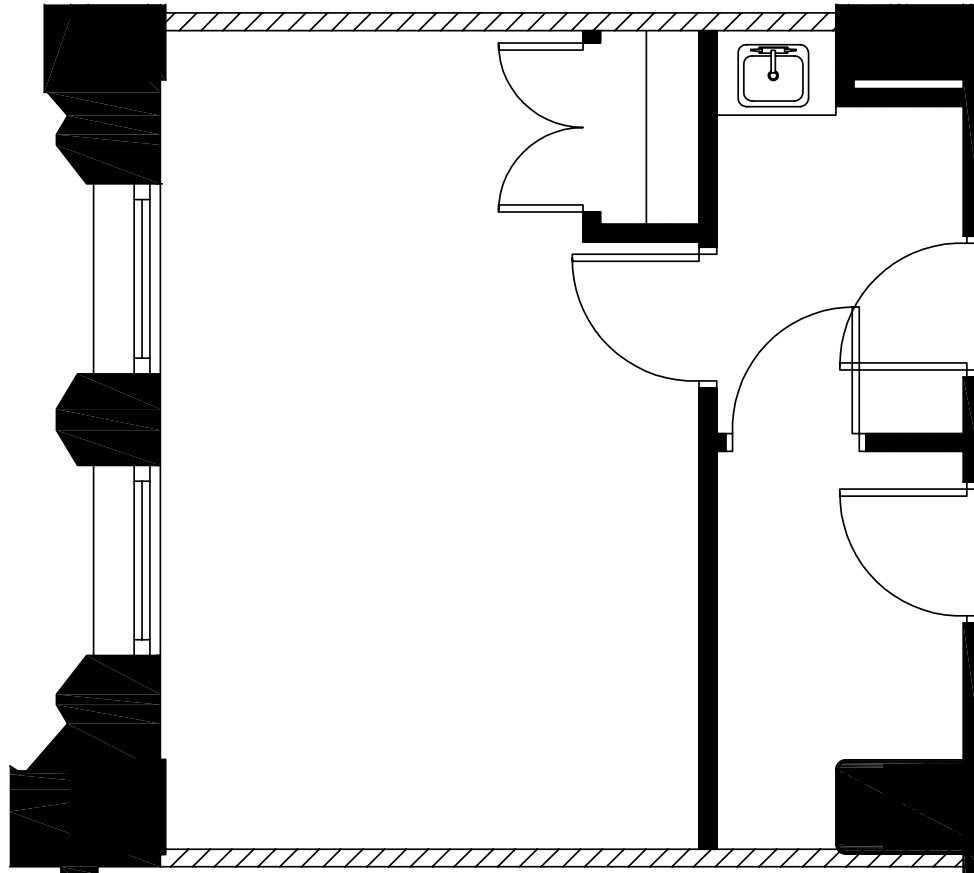
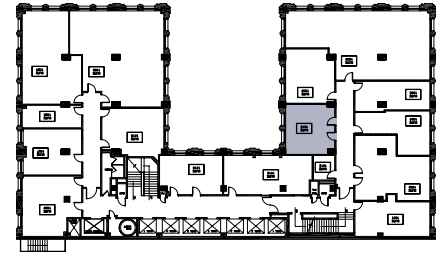

## SUITE 1010

470 RSF

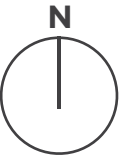

**CANDICE WELLS**

Leasing Agent  
312.884.5452 | [cwells@marcrealty.com](mailto:cwells@marcrealty.com)

55 E Jackson Blvd, Suite 500  
Chicago, IL 60604



Exceptional Value  
Remarkable Locations

# 30

NORTH MICHIGAN  
AVENUE

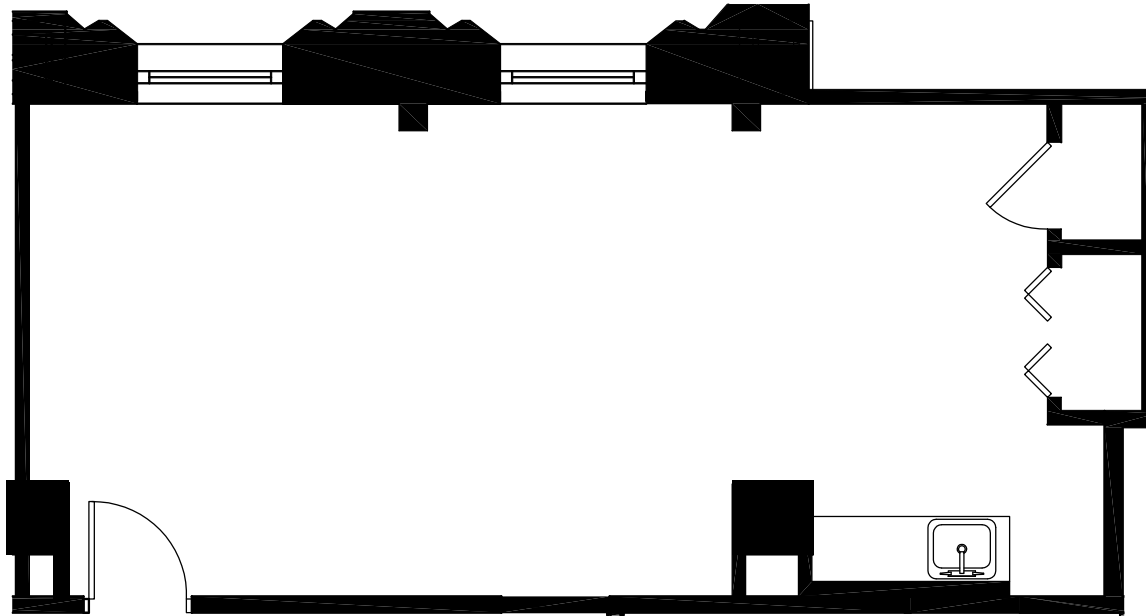
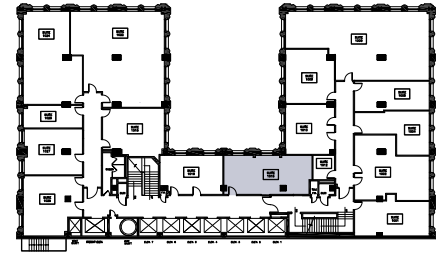

## SUITE 1015

613 RSF

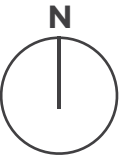

**CANDICE WELLS**

Leasing Agent  
312.884.5452 | [cwells@marcrealty.com](mailto:cwells@marcrealty.com)

55 E Jackson Blvd, Suite 500  
Chicago, IL 60604



Exceptional Value  
Remarkable Locations

# 30

NORTH MICHIGAN  
AVENUE

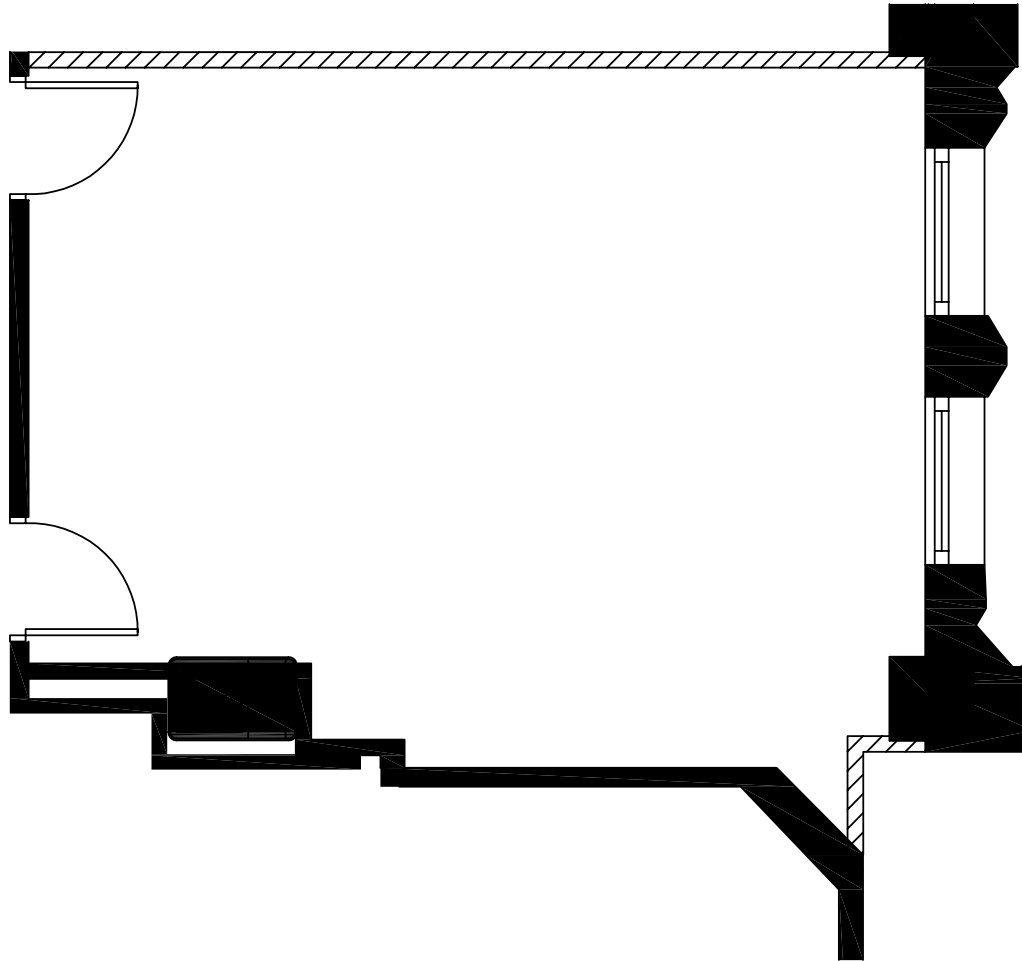
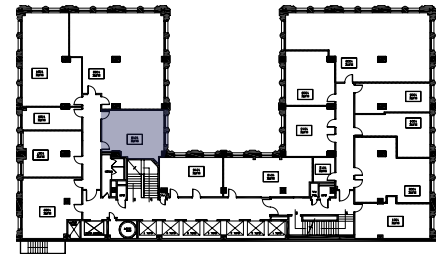

## SUITE 1018

515 RSF

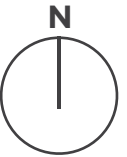

**CANDICE WELLS**

Leasing Agent  
312.884.5452 | [cwells@marcrealty.com](mailto:cwells@marcrealty.com)

55 E Jackson Blvd, Suite 500  
Chicago, IL 60604



Exceptional Value  
Remarkable Locations



# 30

NORTH MICHIGAN  
AVENUE

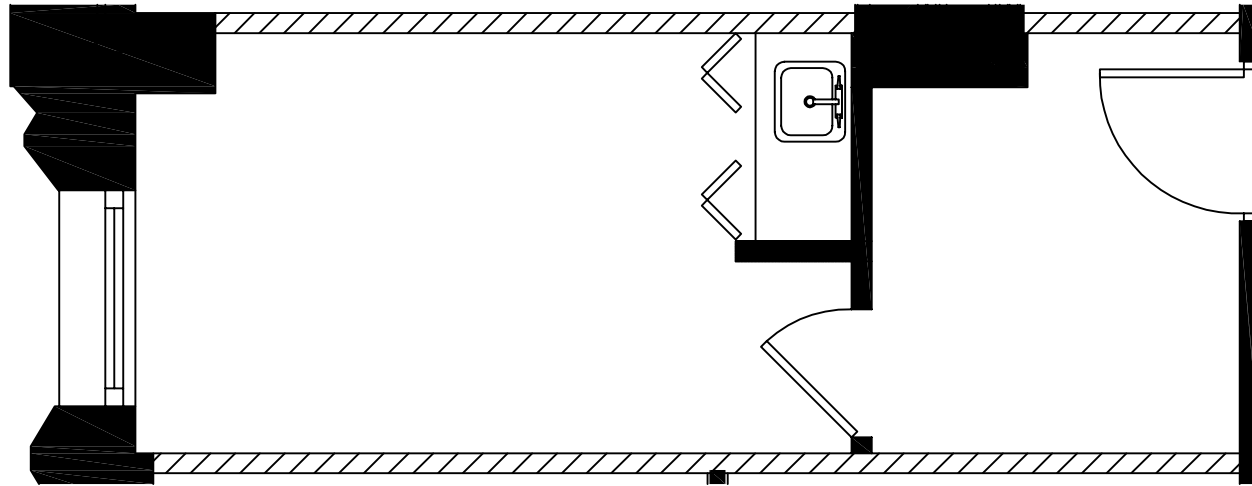
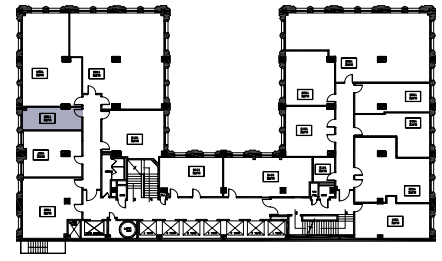

## SUITE 1025

275 RSF



**CANDICE WELLS**

Leasing Agent  
312.884.5452 | [cwells@marcrealty.com](mailto:cwells@marcrealty.com)

55 E Jackson Blvd, Suite 500  
Chicago, IL 60604



Exceptional Value  
Remarkable Locations

# 30

NORTH MICHIGAN  
AVENUE

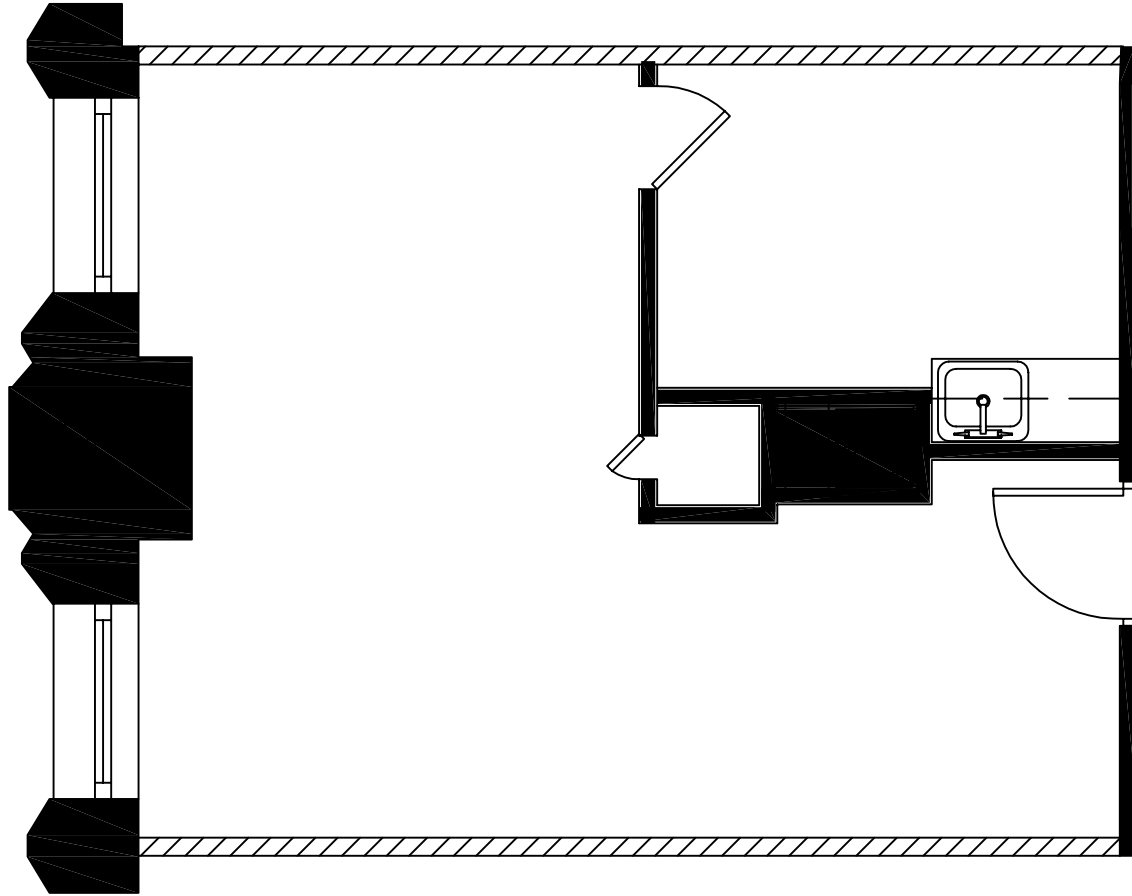
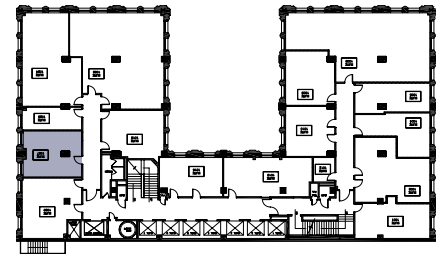

## SUITE 1027

497 RSF

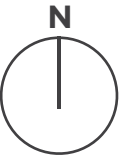

**CANDICE WELLS**

Leasing Agent  
312.884.5452 | [cwells@marcrealty.com](mailto:cwells@marcrealty.com)

55 E Jackson Blvd, Suite 500  
Chicago, IL 60604



Exceptional Value  
Remarkable Locations

# 30

NORTH MICHIGAN  
AVENUE

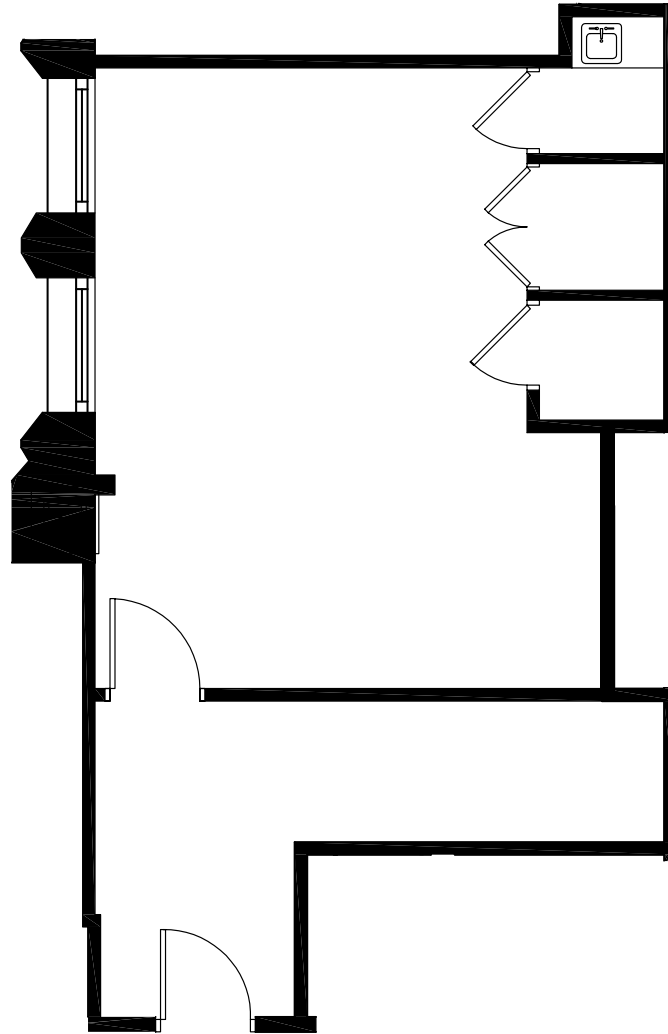
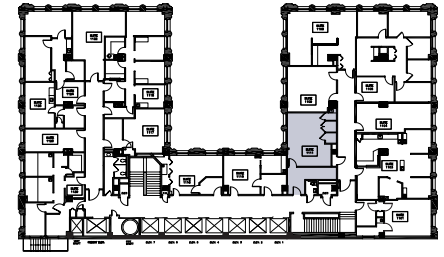

**SUITE 1111**  
**607 RSF**

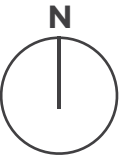

**CANDICE WELLS**

Leasing Agent  
312.884.5452 | [cwells@marcrealty.com](mailto:cwells@marcrealty.com)

55 E Jackson Blvd, Suite 500  
Chicago, IL 60604



Exceptional Value  
Remarkable Locations

# 30

NORTH MICHIGAN  
AVENUE

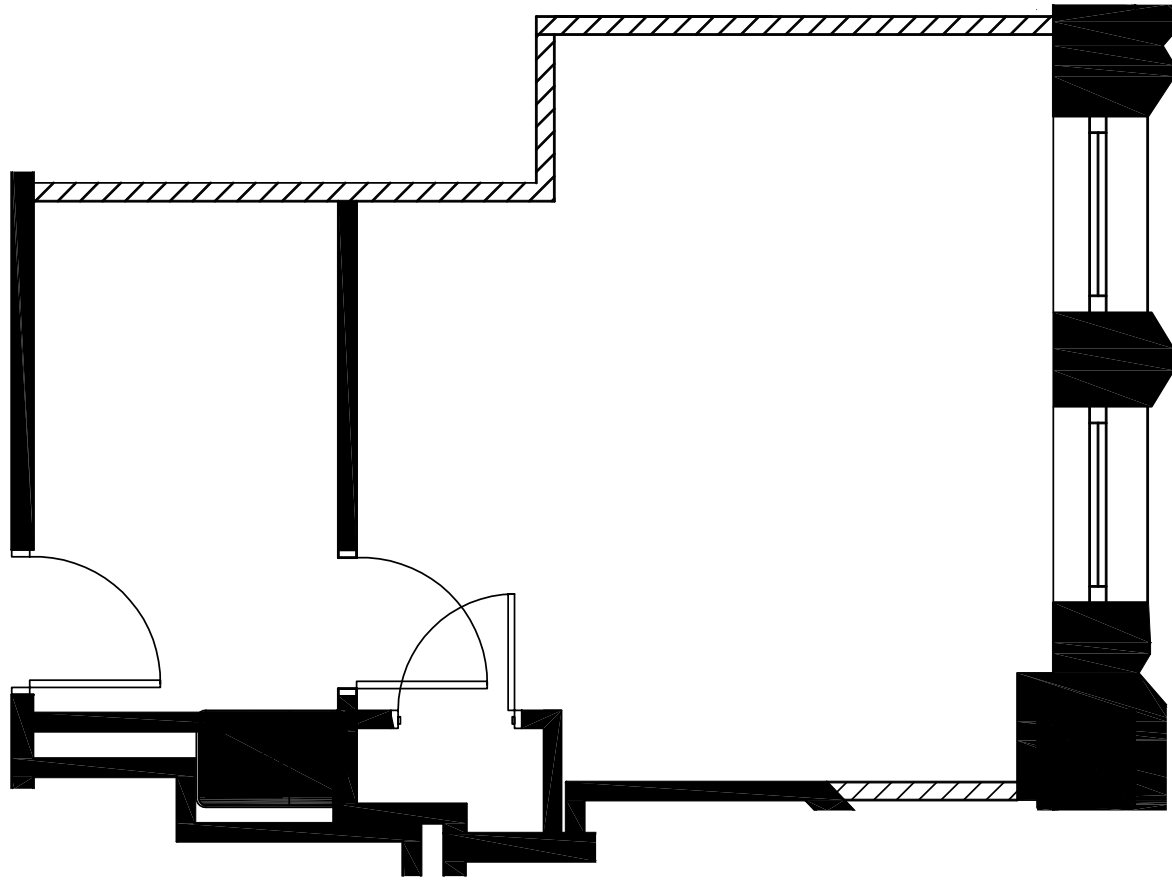
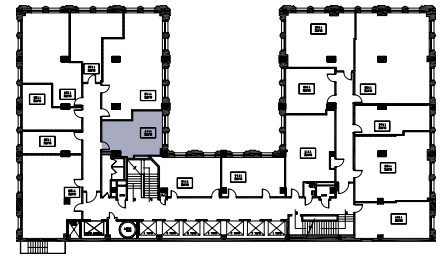

## SUITE 1117

457 RSF

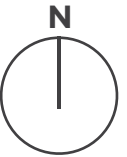

**CANDICE WELLS**

Leasing Agent  
312.884.5452 | [cwells@marcrealty.com](mailto:cwells@marcrealty.com)

55 E Jackson Blvd, Suite 500  
Chicago, IL 60604



Exceptional Value  
Remarkable Locations

# 30

NORTH MICHIGAN  
AVENUE

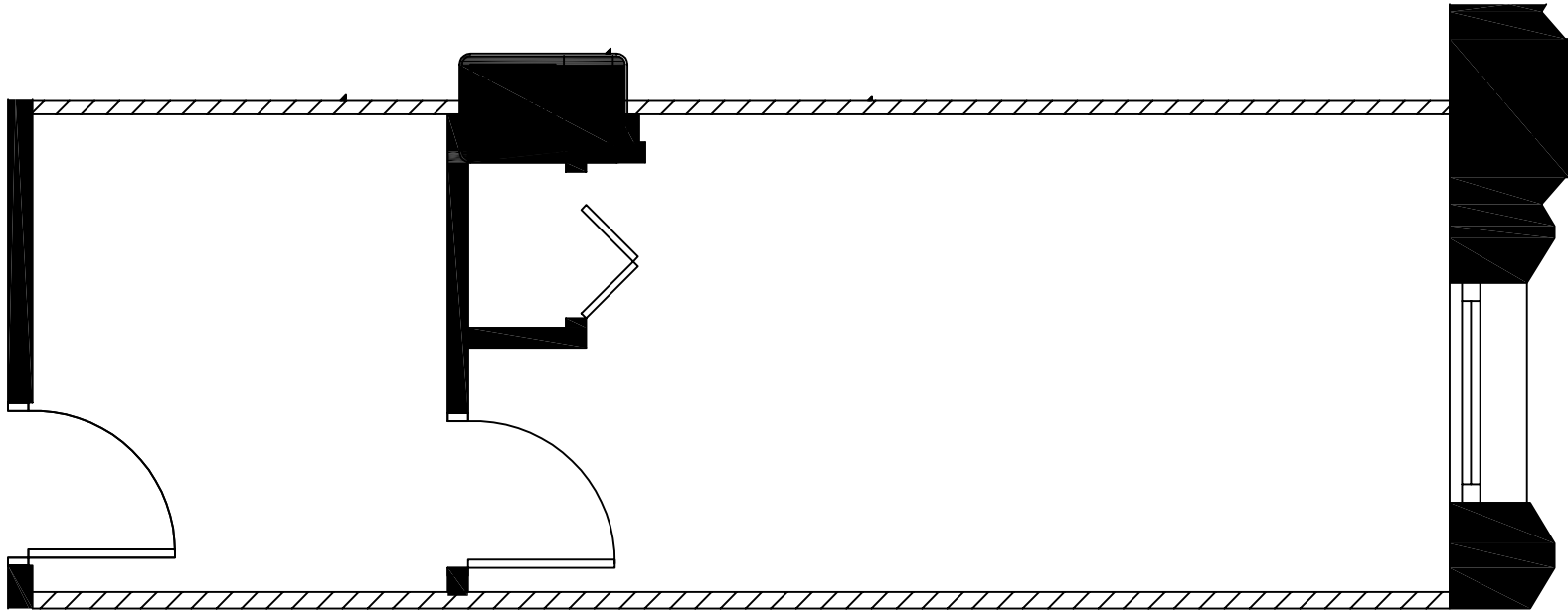
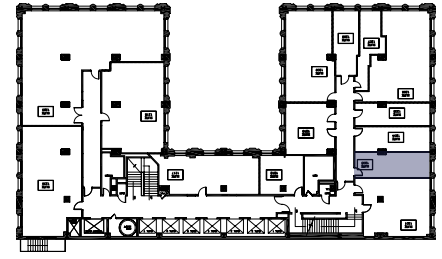

## SUITE 1203

350 RSF

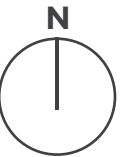

**CANDICE WELLS**

Leasing Agent  
312.884.5452 | [cwells@marcrealty.com](mailto:cwells@marcrealty.com)

55 E Jackson Blvd, Suite 500  
Chicago, IL 60604



Exceptional Value  
Remarkable Locations



# 30

NORTH MICHIGAN  
AVENUE

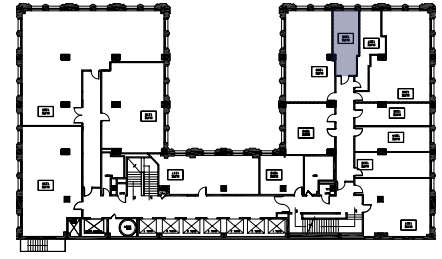
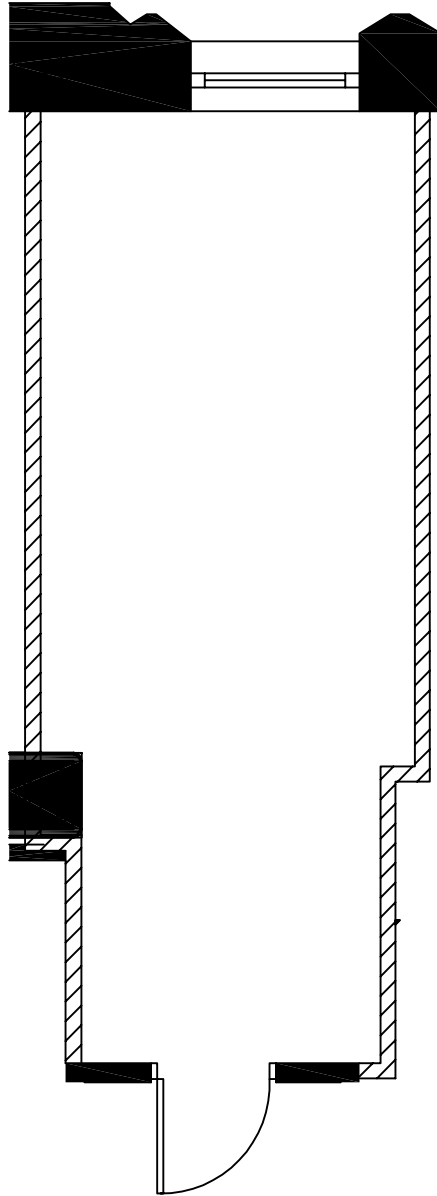

## SUITE 1208

240 RSF

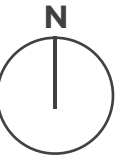

**CANDICE WELLS**

Leasing Agent  
312.884.5452 | [cwells@marcrealty.com](mailto:cwells@marcrealty.com)

55 E Jackson Blvd, Suite 500  
Chicago, IL 60604



Exceptional Value  
Remarkable Locations

# 30

NORTH MICHIGAN  
AVENUE

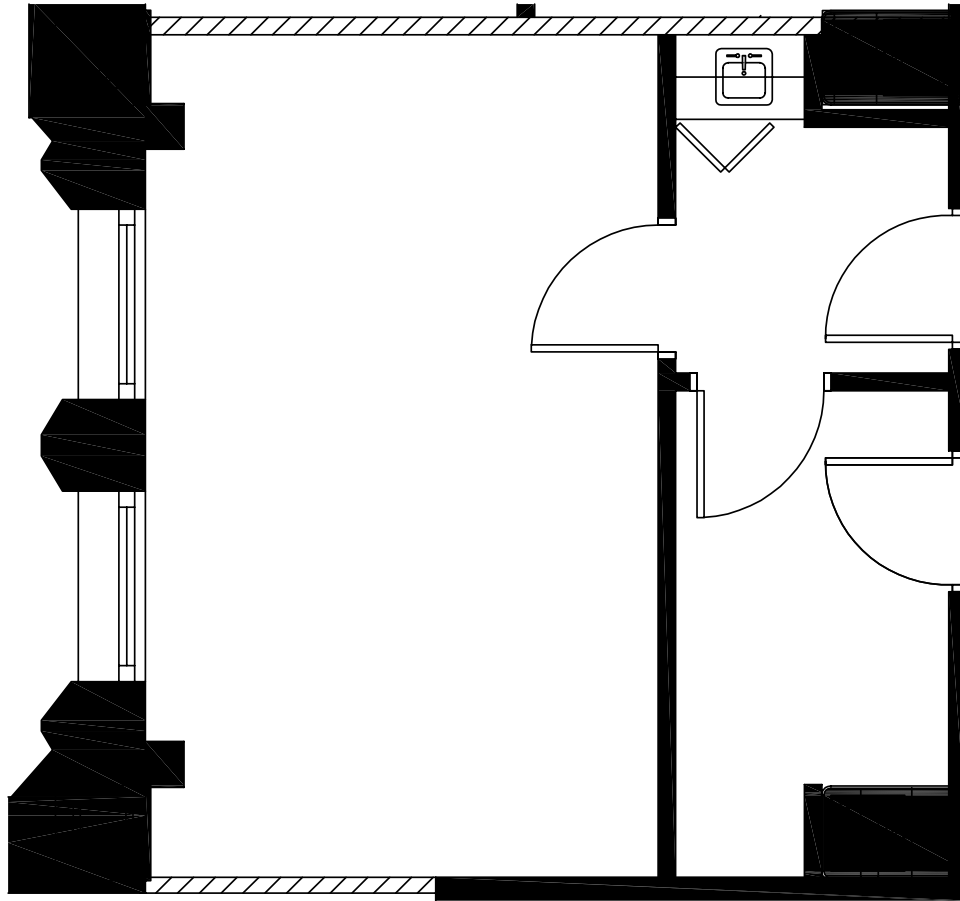
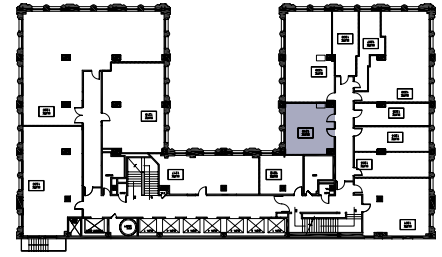

## SUITE 1210

452 RSF

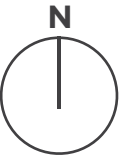

**CANDICE WELLS**

Leasing Agent  
312.884.5452 | [cwells@marcrealty.com](mailto:cwells@marcrealty.com)

55 E Jackson Blvd, Suite 500  
Chicago, IL 60604



Exceptional Value  
Remarkable Locations

# 30

NORTH MICHIGAN  
AVENUE

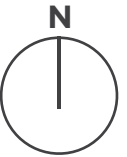
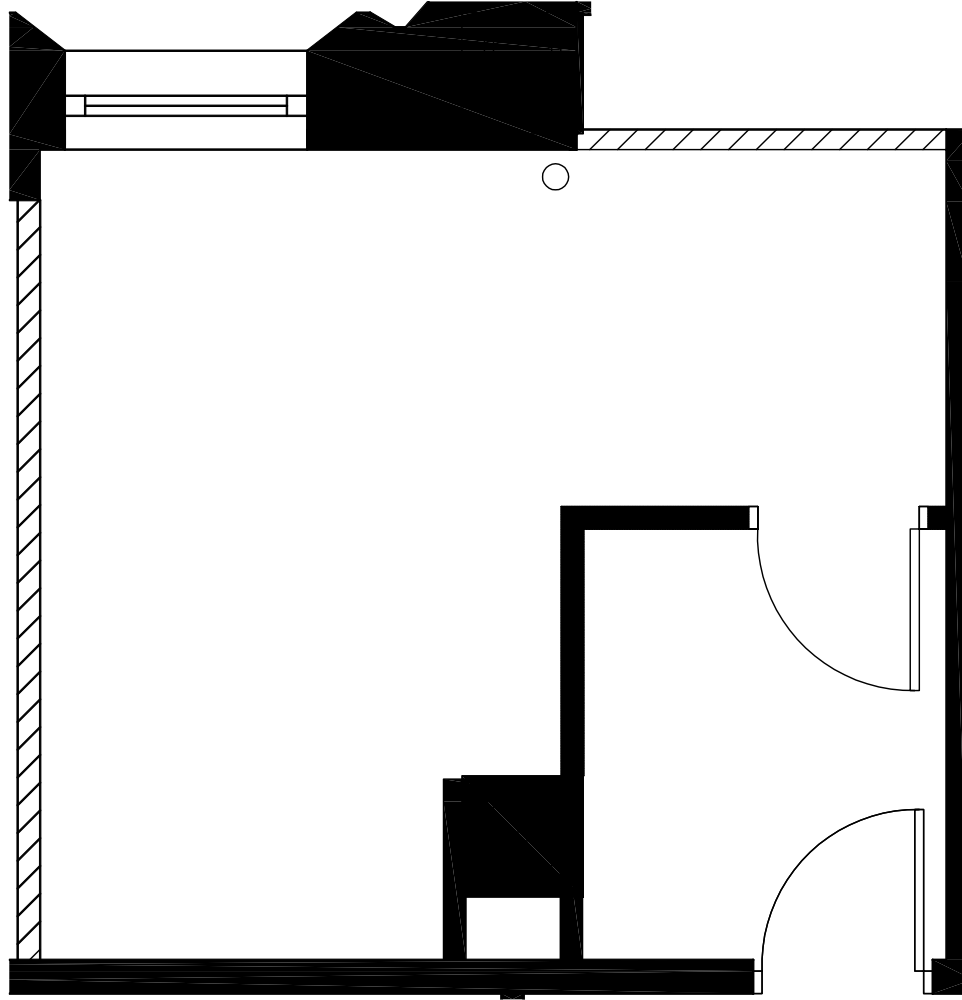
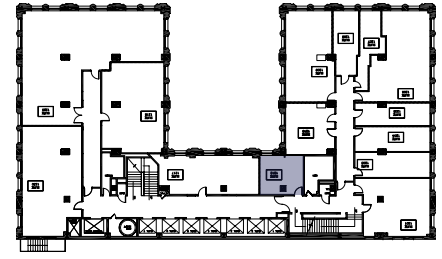

**SUITE 1212**  
**330 RSF**

**CANDICE WELLS**

Leasing Agent  
312.884.5452 | [cwells@marcrealty.com](mailto:cwells@marcrealty.com)

55 E Jackson Blvd, Suite 500  
Chicago, IL 60604



Exceptional Value  
Remarkable Locations

# 30

NORTH MICHIGAN  
AVENUE

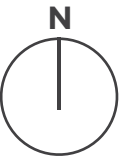
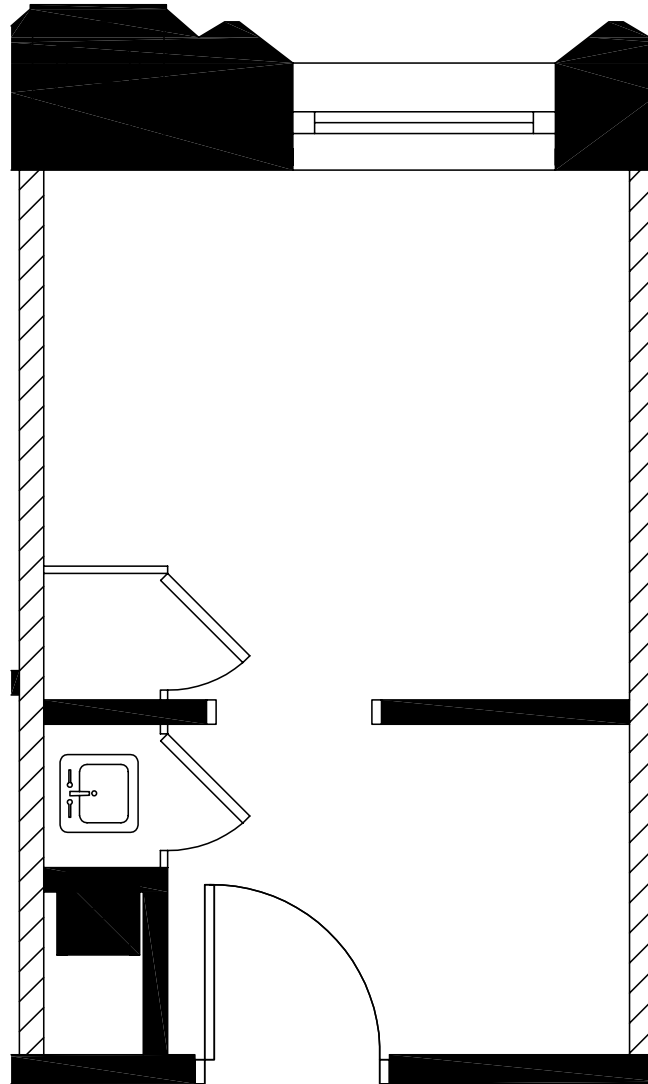
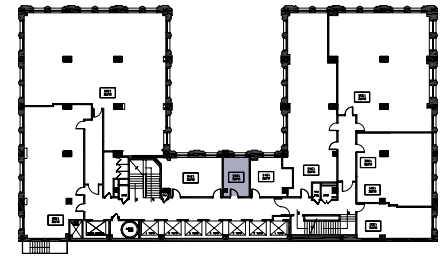

## SUITE 1315

229 RSF

**CANDICE WELLS**

Leasing Agent  
312.884.5452 | [cwells@marcrealty.com](mailto:cwells@marcrealty.com)

55 E Jackson Blvd, Suite 500  
Chicago, IL 60604



Exceptional Value  
Remarkable Locations

# 30

NORTH MICHIGAN  
AVENUE

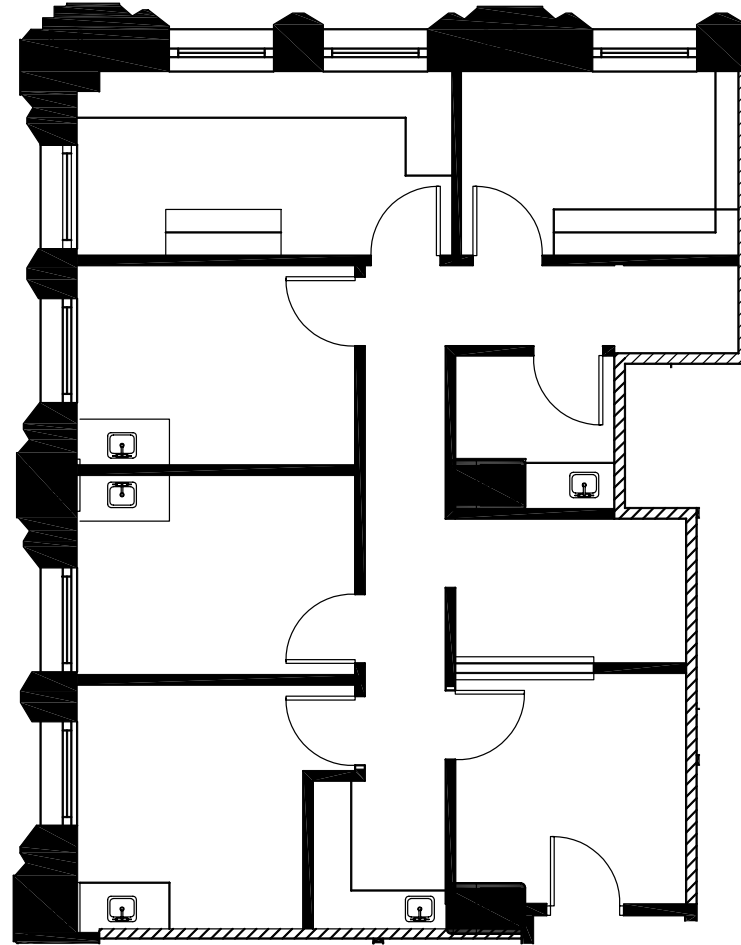
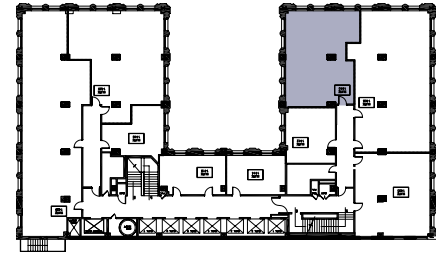

## SUITE 1410

1,299 RSF

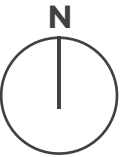

**CANDICE WELLS**

Leasing Agent  
312.884.5452 | [cwells@marcrealty.com](mailto:cwells@marcrealty.com)

55 E Jackson Blvd, Suite 500  
Chicago, IL 60604



Exceptional Value  
Remarkable Locations

# 30

NORTH MICHIGAN  
AVENUE

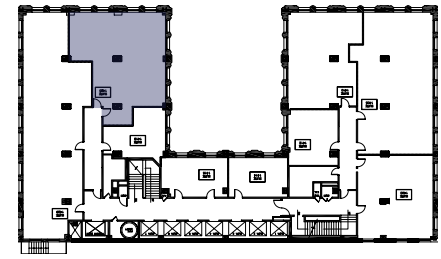
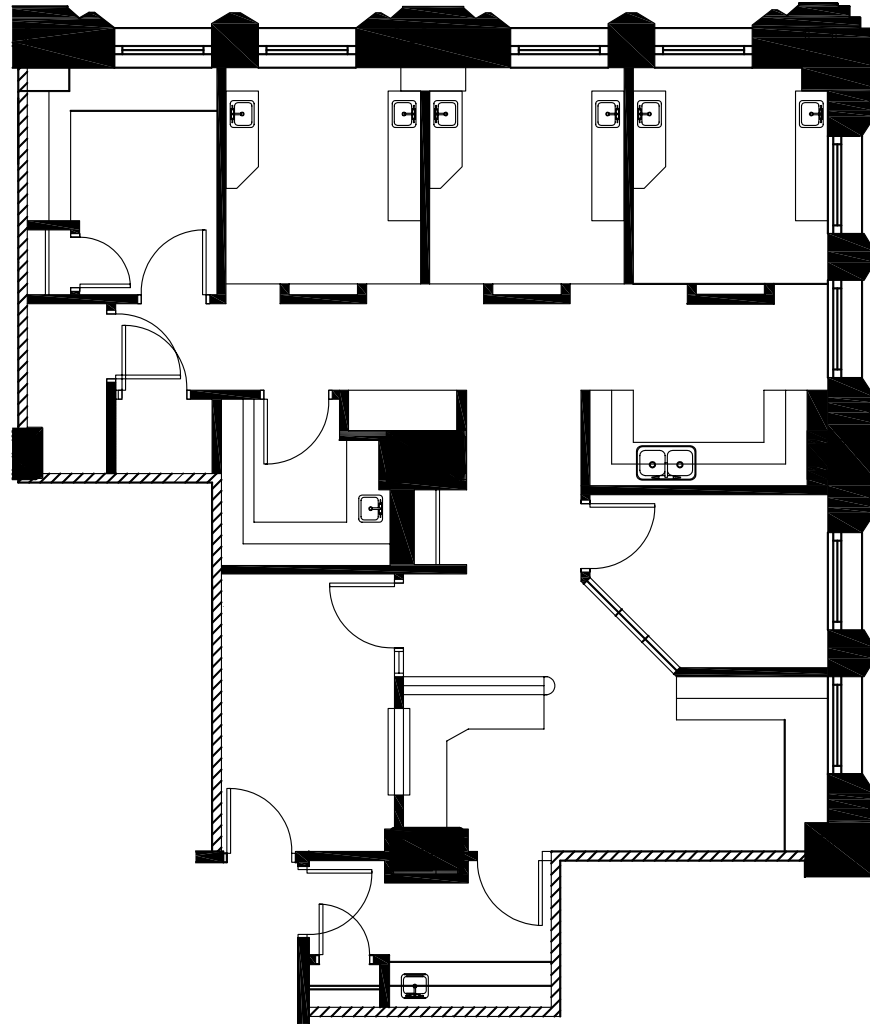

## SUITE 1420

1,532 RSF

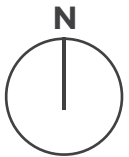

**CANDICE WELLS**

Leasing Agent  
312.884.5452 | [cwells@marcrealty.com](mailto:cwells@marcrealty.com)

55 E Jackson Blvd, Suite 500  
Chicago, IL 60604



Exceptional Value  
Remarkable Locations



# 30

NORTH MICHIGAN  
AVENUE

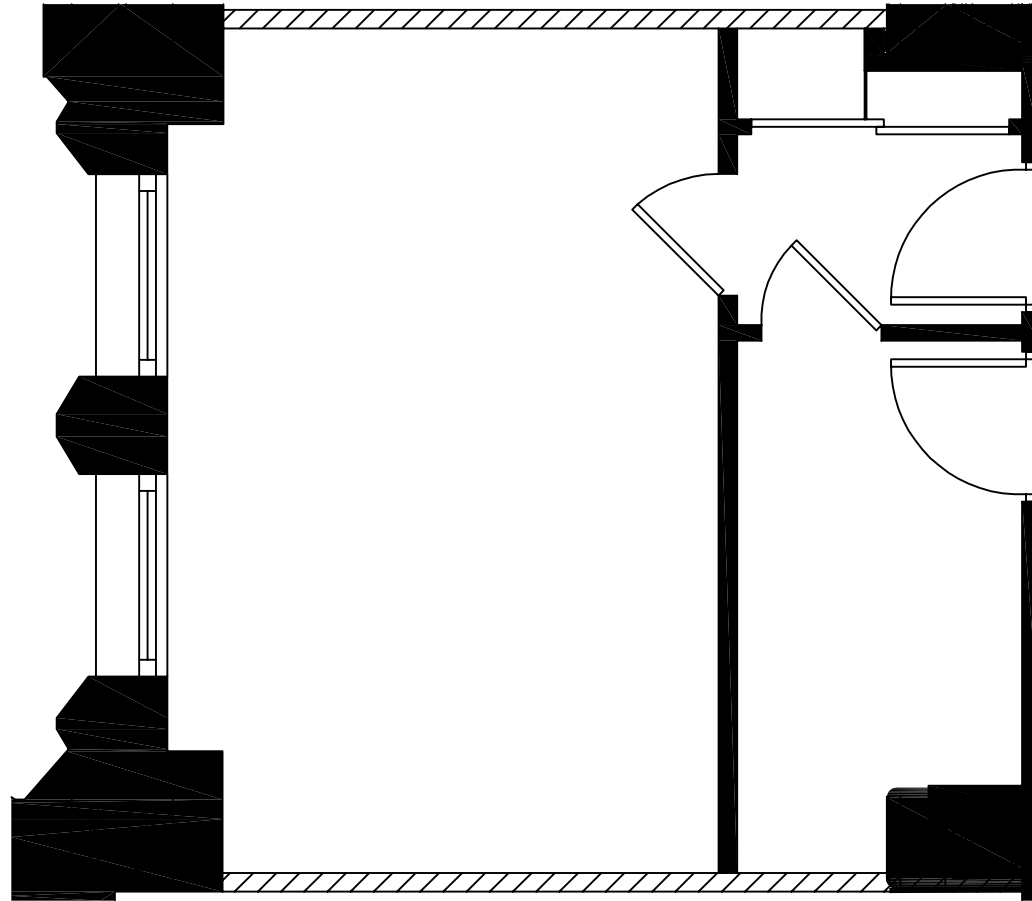
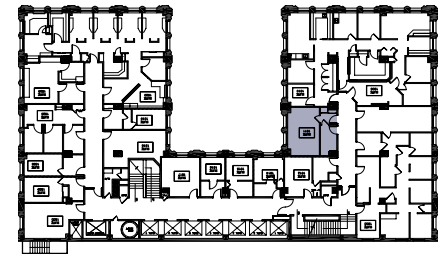

## SUITE 1511

476 RSF

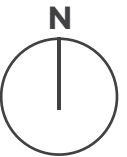

### CANDICE WELLS

Leasing Agent  
312.884.5452 | [cwells@marcrealty.com](mailto:cwells@marcrealty.com)

55 E Jackson Blvd, Suite 500  
Chicago, IL 60604



Exceptional Value  
Remarkable Locations

# 30

NORTH MICHIGAN  
AVENUE

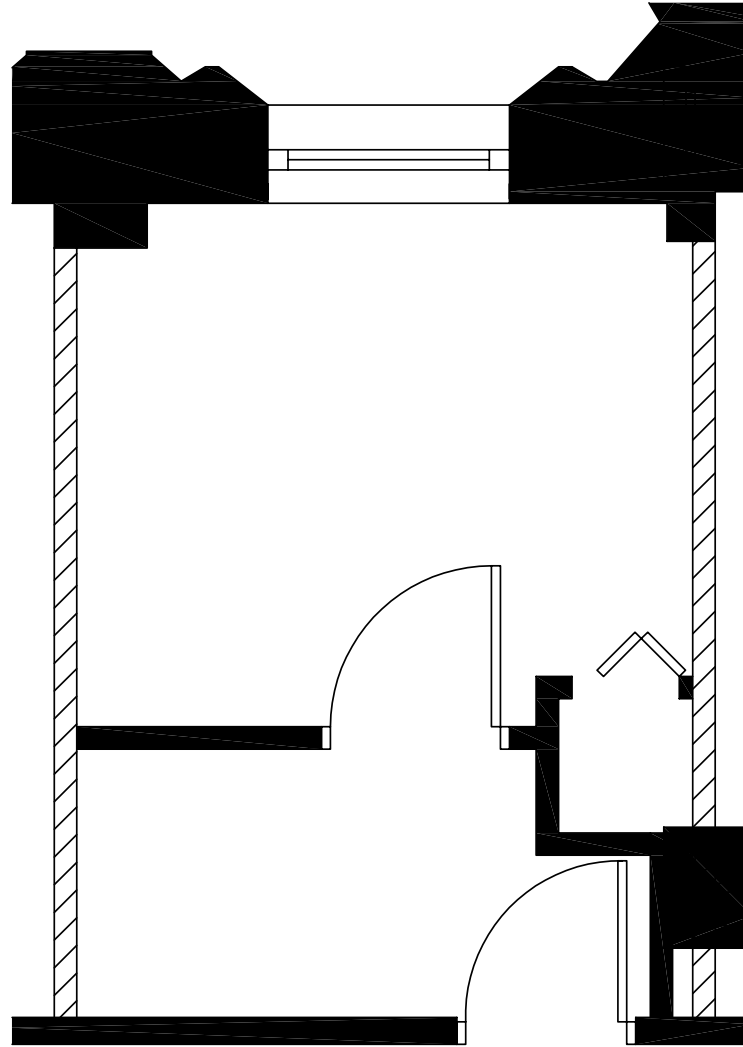
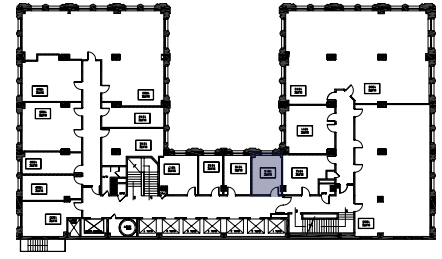

## SUITE 1514

219 RSF

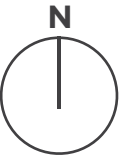

**CANDICE WELLS**

Leasing Agent  
312.884.5452 | [cwells@marcrealty.com](mailto:cwells@marcrealty.com)

55 E Jackson Blvd, Suite 500  
Chicago, IL 60604



Exceptional Value  
Remarkable Locations

# 30

NORTH MICHIGAN  
AVENUE

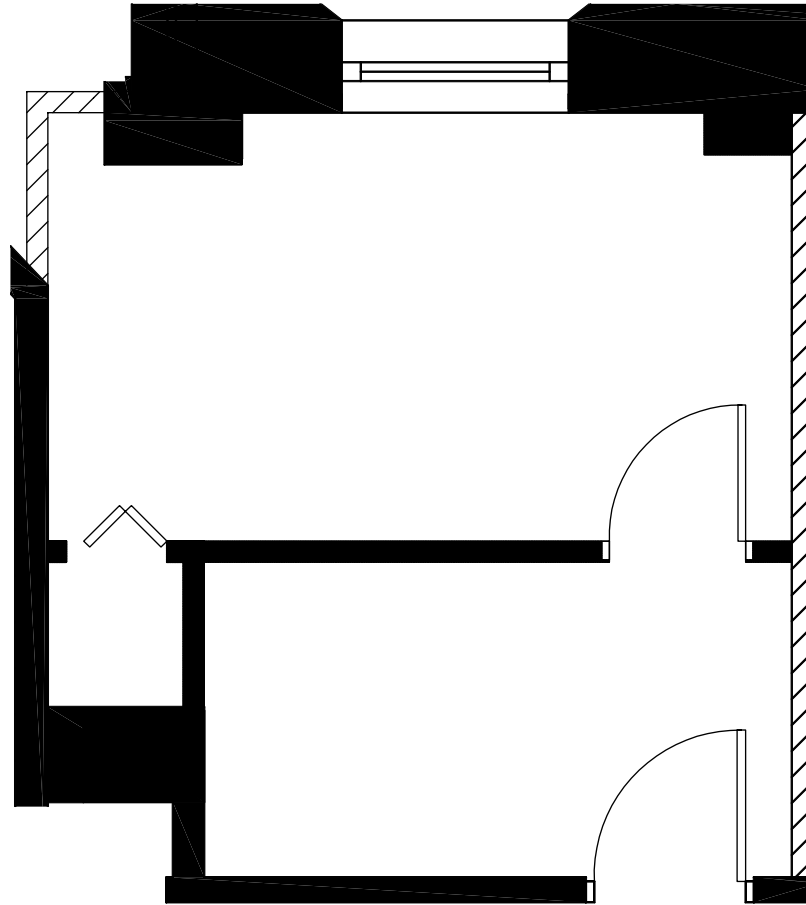
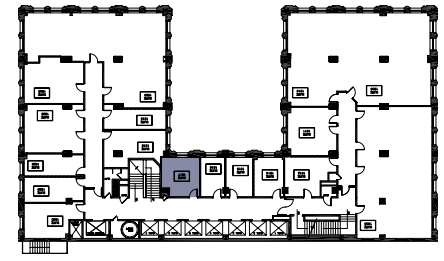

## SUITE 1517

337 RSF

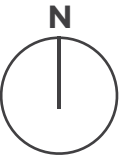

**CANDICE WELLS**

Leasing Agent  
312.884.5452 | [cwells@marcrealty.com](mailto:cwells@marcrealty.com)

55 E Jackson Blvd, Suite 500  
Chicago, IL 60604



Exceptional Value  
Remarkable Locations

# 30

NORTH MICHIGAN  
AVENUE

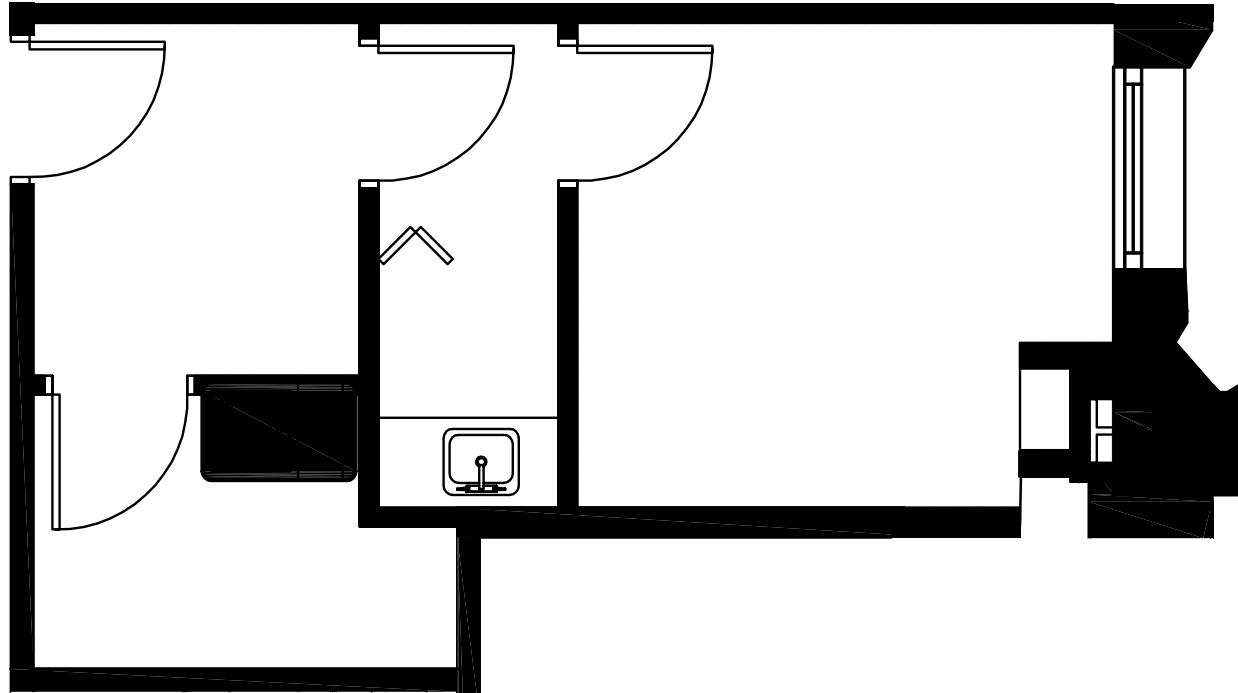
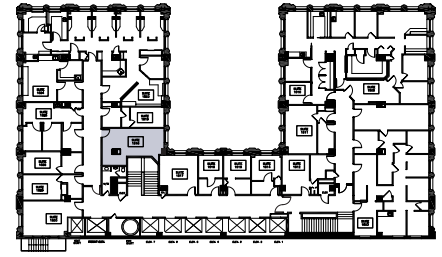

## SUITE 1518

320 RSF

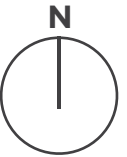

**CANDICE WELLS**

Leasing Agent  
312.884.5452 | [cwells@marcrealty.com](mailto:cwells@marcrealty.com)

55 E Jackson Blvd, Suite 500  
Chicago, IL 60604



Exceptional Value  
Remarkable Locations

# 30

NORTH MICHIGAN  
AVENUE

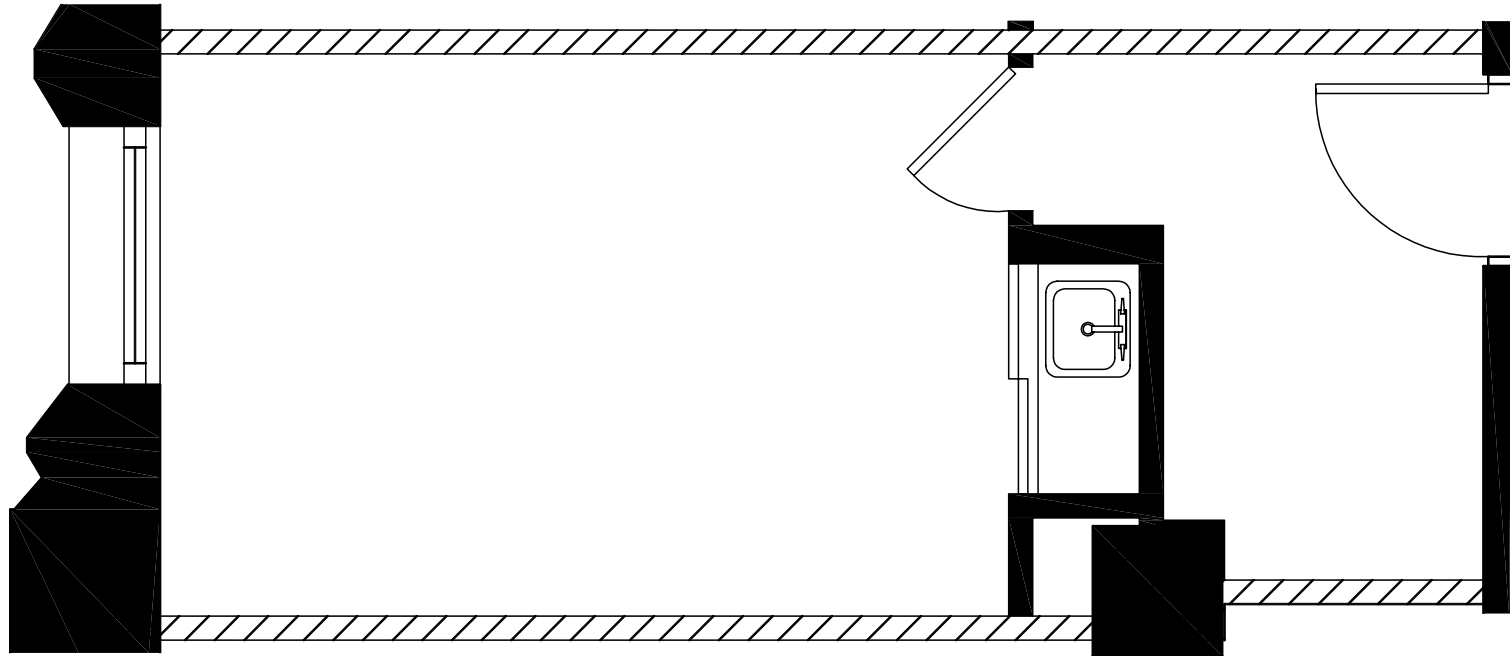
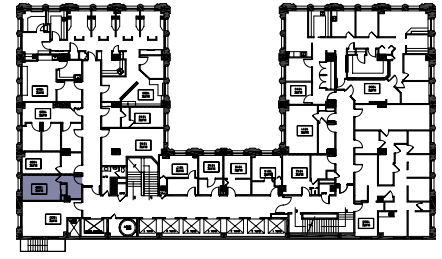

## SUITE 1529

309 RSF

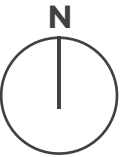

**CANDICE WELLS**

Leasing Agent  
312.884.5452 | [cwells@marcrealty.com](mailto:cwells@marcrealty.com)

55 E Jackson Blvd, Suite 500  
Chicago, IL 60604



Exceptional Value  
Remarkable Locations

# 30

NORTH MICHIGAN  
AVENUE

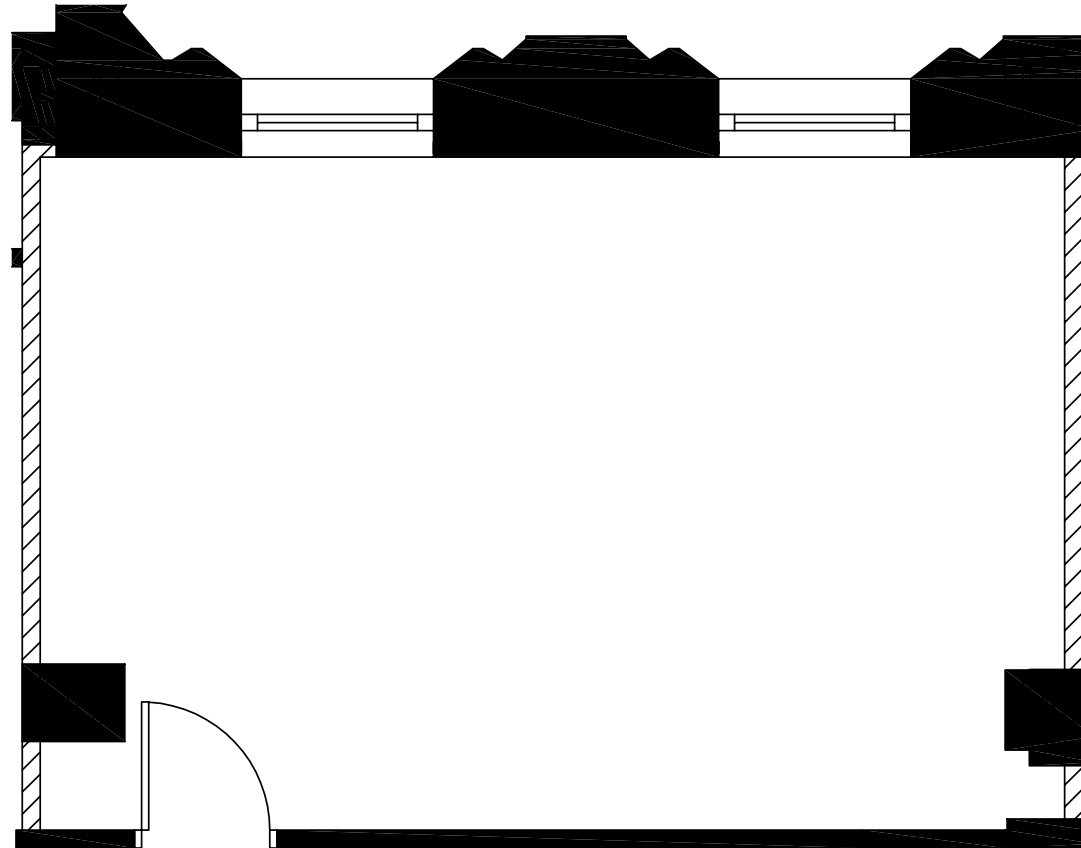
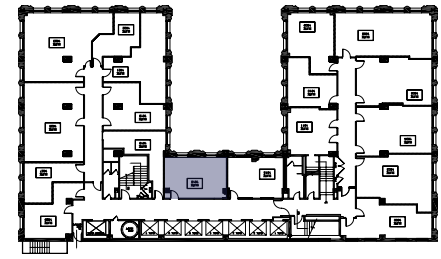

## SUITE 1617

447 RSF

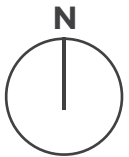

### CANDICE WELLS

Leasing Agent  
312.884.5452 | [cwells@marcrealty.com](mailto:cwells@marcrealty.com)

55 E Jackson Blvd, Suite 500  
Chicago, IL 60604



Exceptional Value  
Remarkable Locations



# 30

NORTH MICHIGAN  
AVENUE

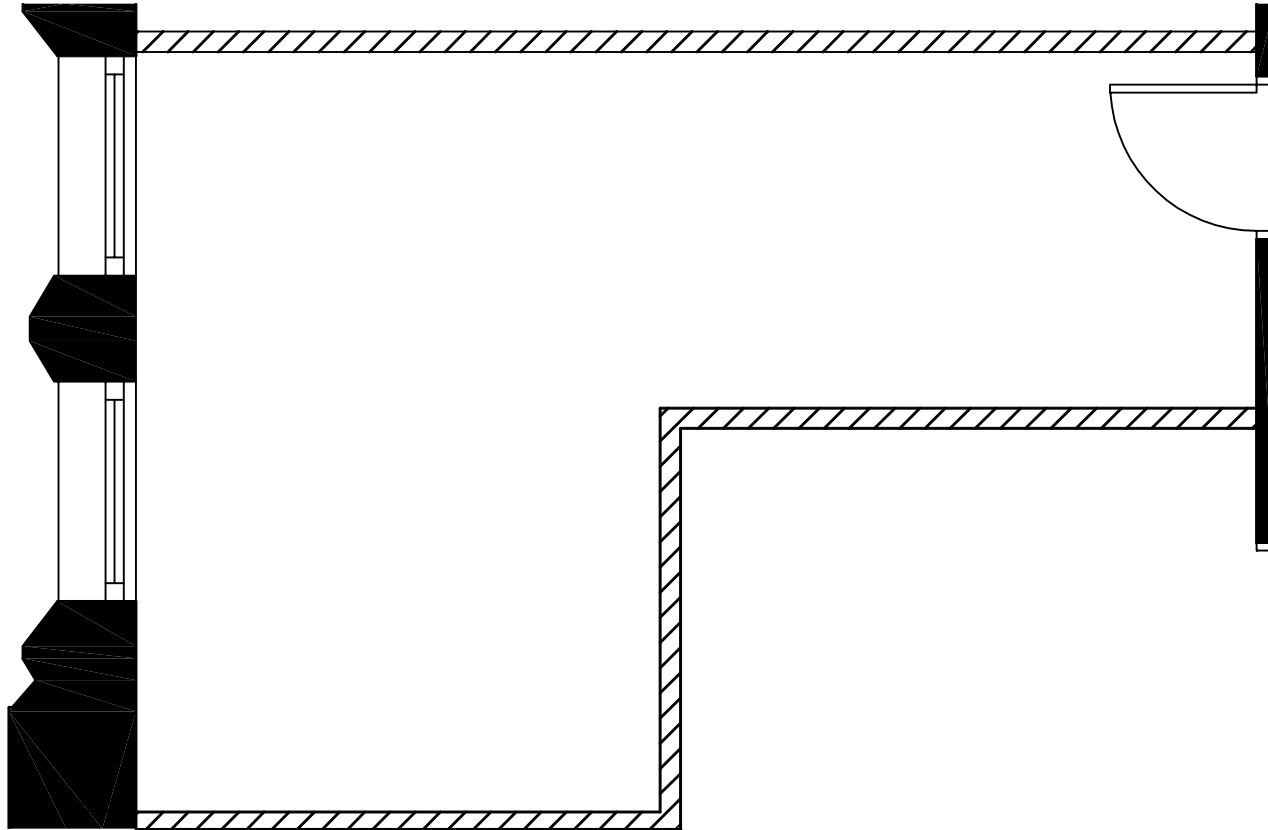
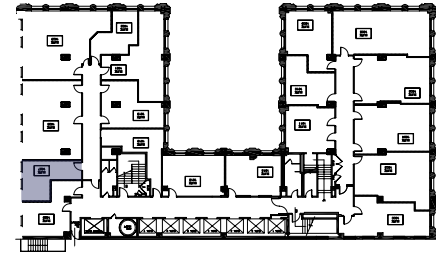

## SUITE 1627

319 RSF



**CANDICE WELLS**

Leasing Agent  
312.884.5452 | [cwells@marcrealty.com](mailto:cwells@marcrealty.com)

55 E Jackson Blvd, Suite 500  
Chicago, IL 60604



Exceptional Value  
Remarkable Locations

# 30

NORTH MICHIGAN  
AVENUE

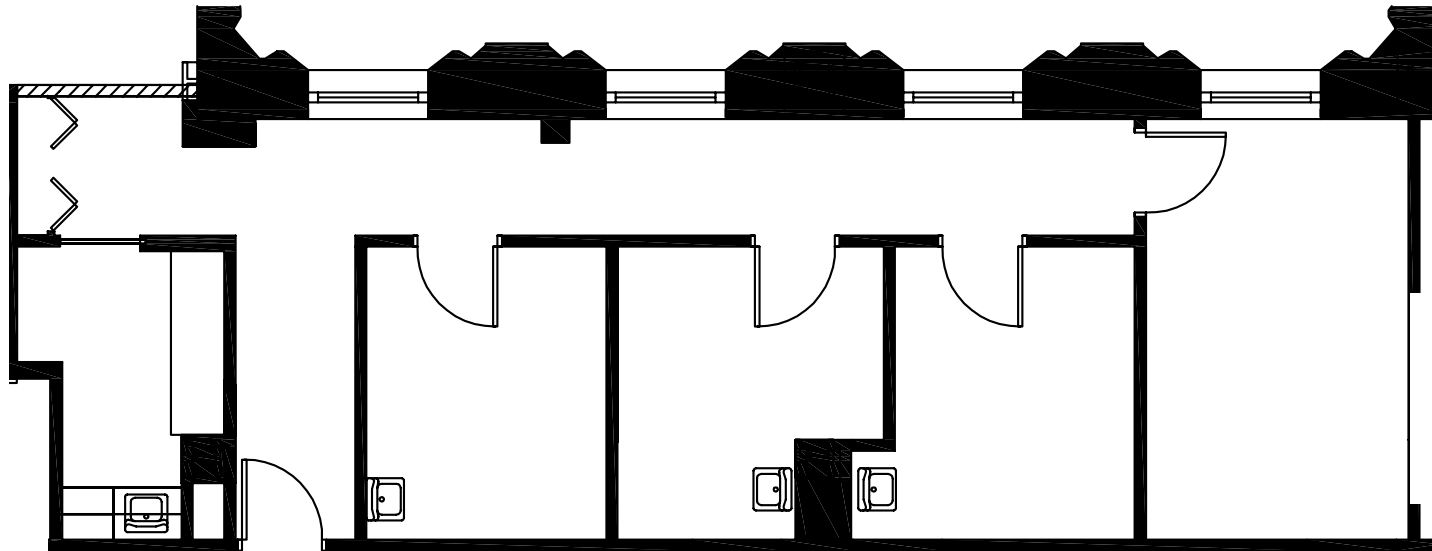
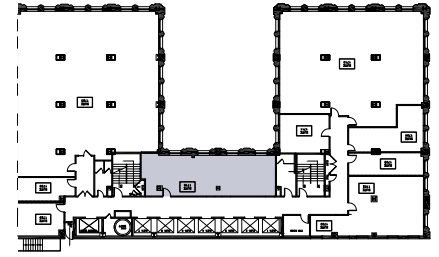

## SUITE 1715

959 RSF

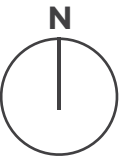

**CANDICE WELLS**

Leasing Agent  
312.884.5452 | [cwells@marcrealty.com](mailto:cwells@marcrealty.com)

55 E Jackson Blvd, Suite 500  
Chicago, IL 60604



Exceptional Value  
Remarkable Locations

# 30

NORTH MICHIGAN  
AVENUE

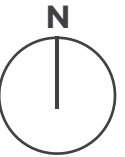
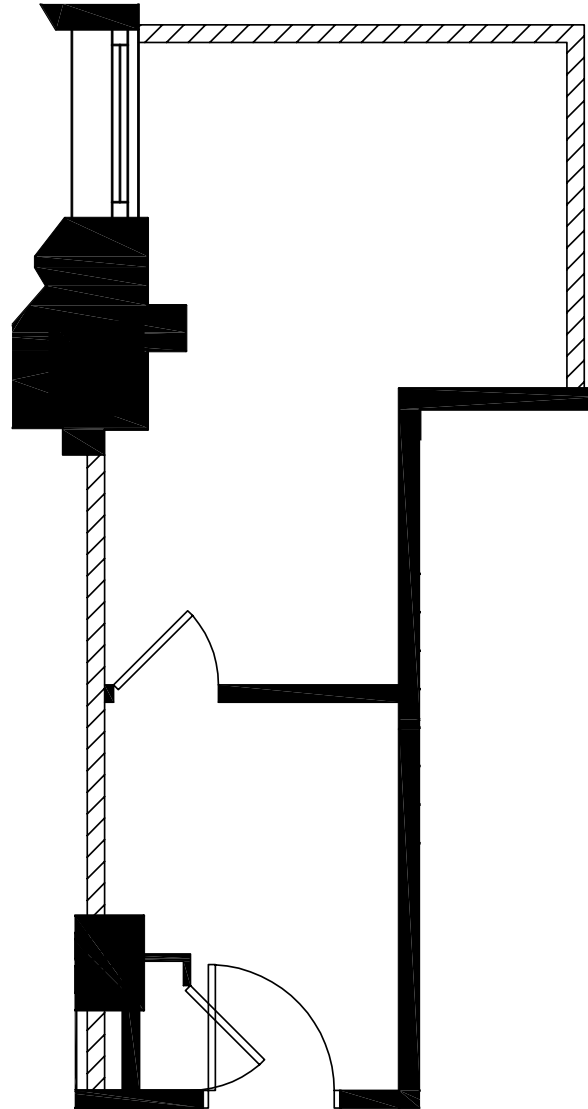
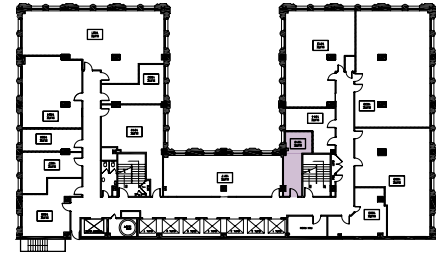

**SUITE 1816**  
**292 RSF**

**CANDICE WELLS**

Leasing Agent  
312.884.5452 | [cwells@marcrealty.com](mailto:cwells@marcrealty.com)

55 E Jackson Blvd, Suite 500  
Chicago, IL 60604



Exceptional Value  
Remarkable Locations

# 30

NORTH MICHIGAN  
AVENUE

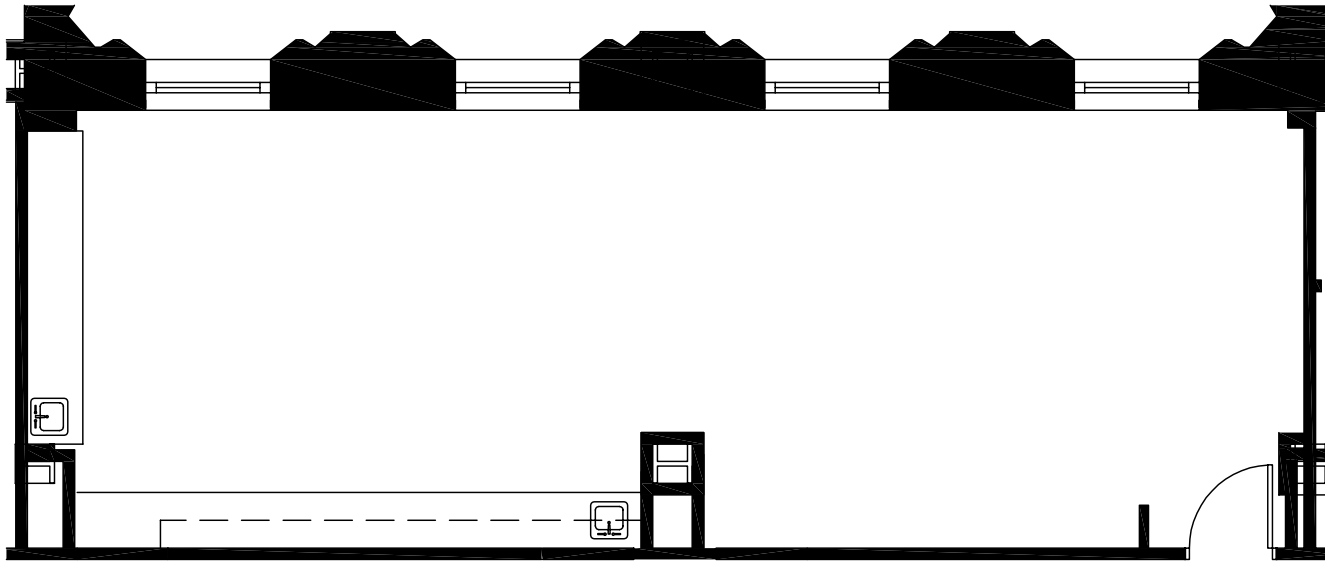
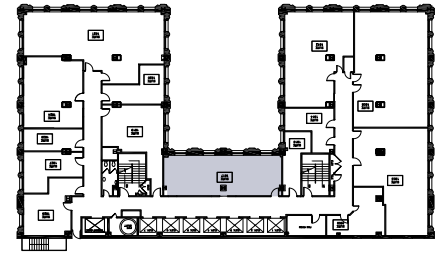

## SUITE 1817

908 RSF

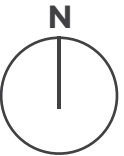

**CANDICE WELLS**

Leasing Agent  
312.884.5452 | [cwells@marcrealty.com](mailto:cwells@marcrealty.com)

55 E Jackson Blvd, Suite 500  
Chicago, IL 60604



Exceptional Value  
Remarkable Locations

# 30

NORTH MICHIGAN  
AVENUE

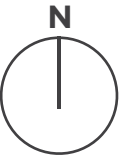
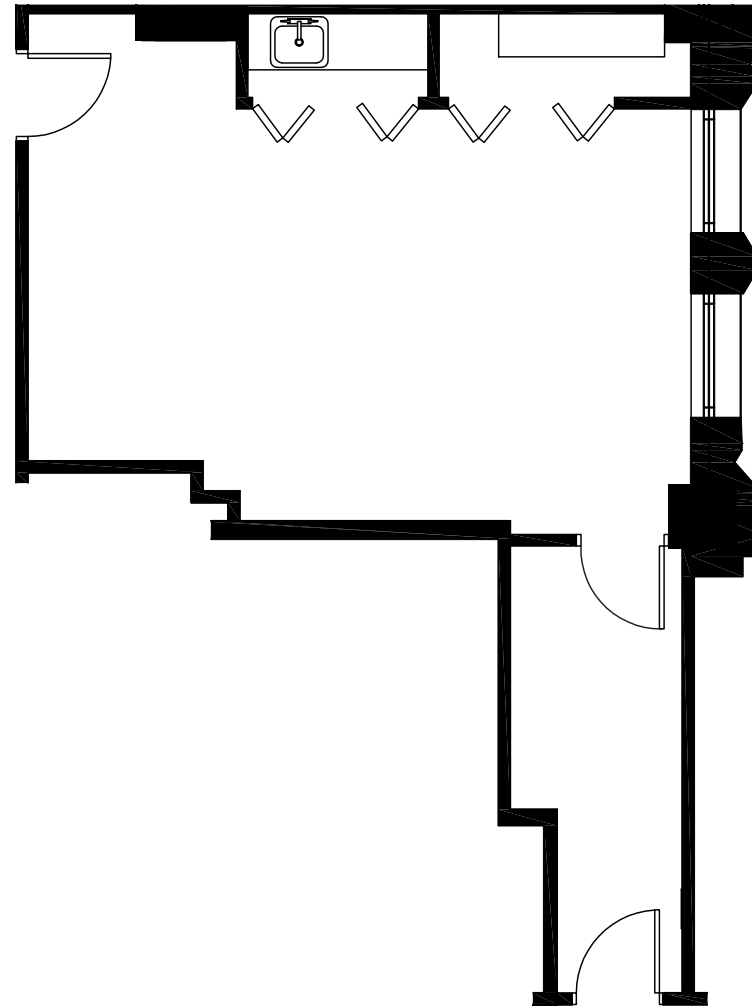
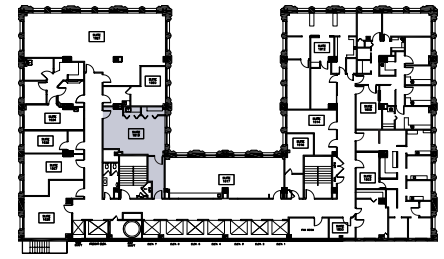

## SUITE 1819

611 RSF

**CANDICE WELLS**

Leasing Agent  
312.884.5452 | [cwells@marcrealty.com](mailto:cwells@marcrealty.com)

55 E Jackson Blvd, Suite 500  
Chicago, IL 60604



Exceptional Value  
Remarkable Locations

# 30

NORTH MICHIGAN  
AVENUE

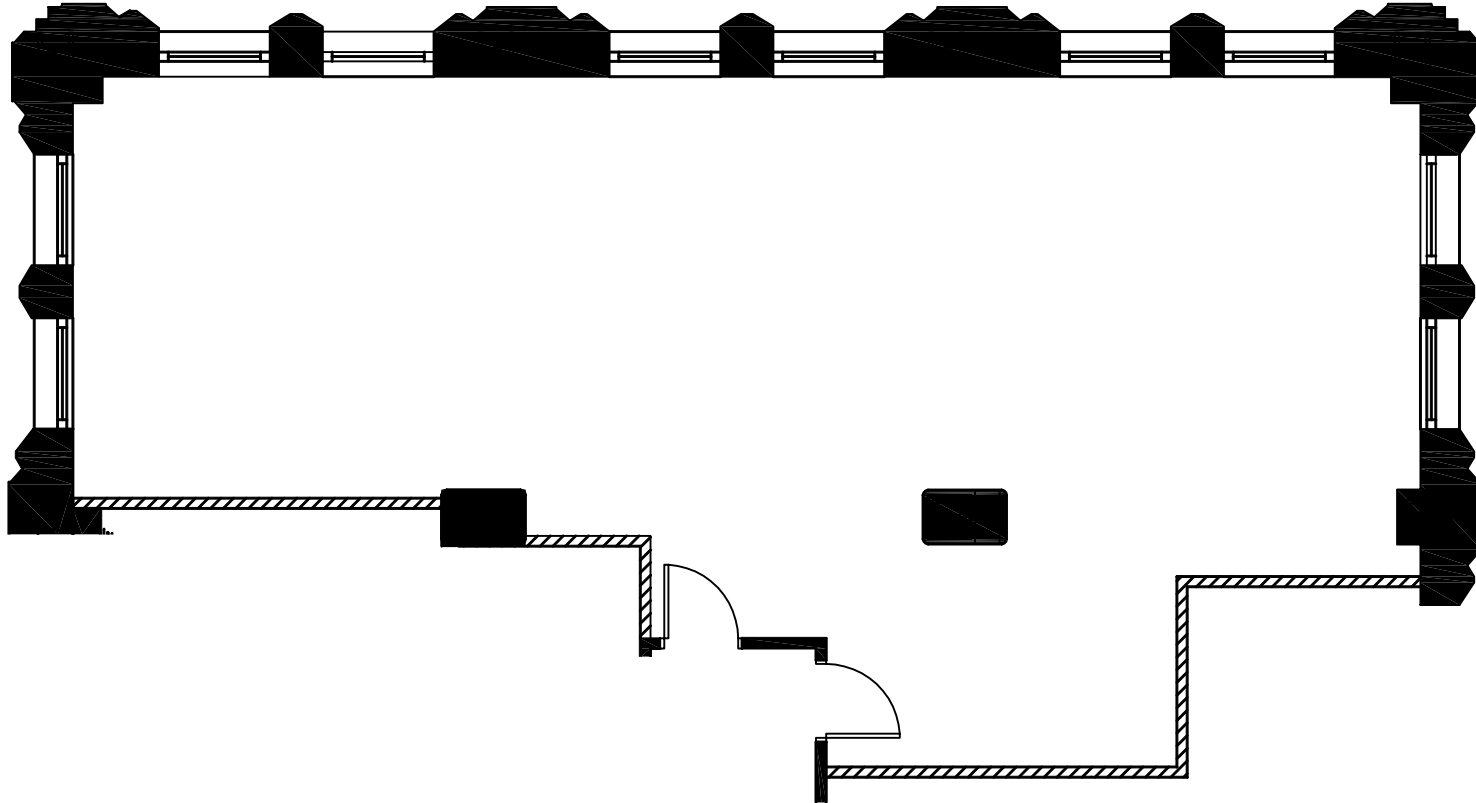
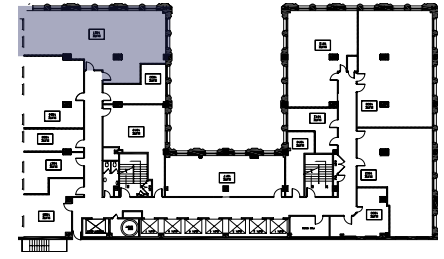

## SUITE 1821

1,444 RSF

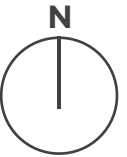

**CANDICE WELLS**

Leasing Agent  
312.884.5452 | [cwells@marcrealty.com](mailto:cwells@marcrealty.com)

55 E Jackson Blvd, Suite 500  
Chicago, IL 60604



Exceptional Value  
Remarkable Locations



# 30

NORTH MICHIGAN  
AVENUE

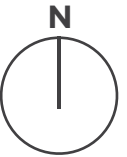
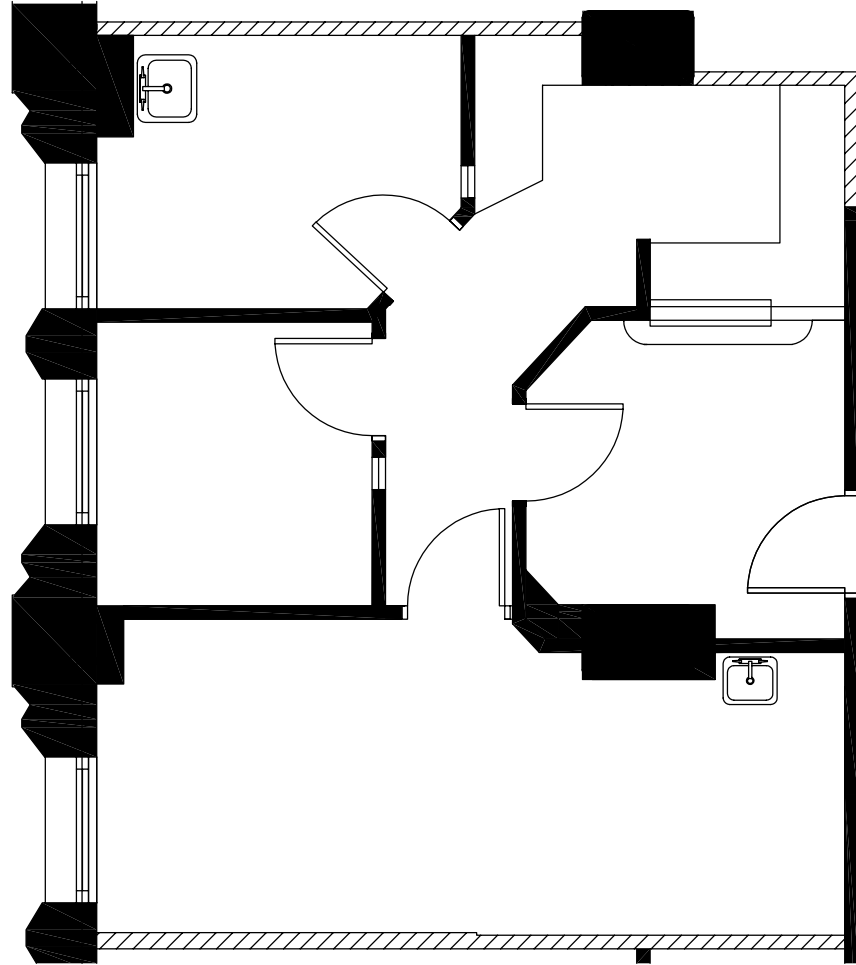
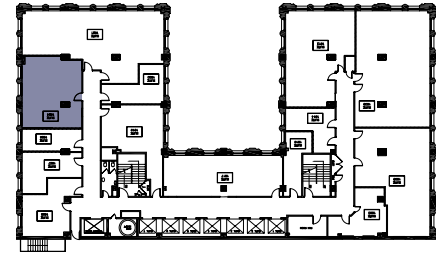

## SUITE 1824

775 RSF

### CANDICE WELLS

Leasing Agent  
312.884.5452 | [cwells@marcrealty.com](mailto:cwells@marcrealty.com)

55 E Jackson Blvd, Suite 500  
Chicago, IL 60604



Exceptional Value  
Remarkable Locations

# 30

NORTH MICHIGAN  
AVENUE

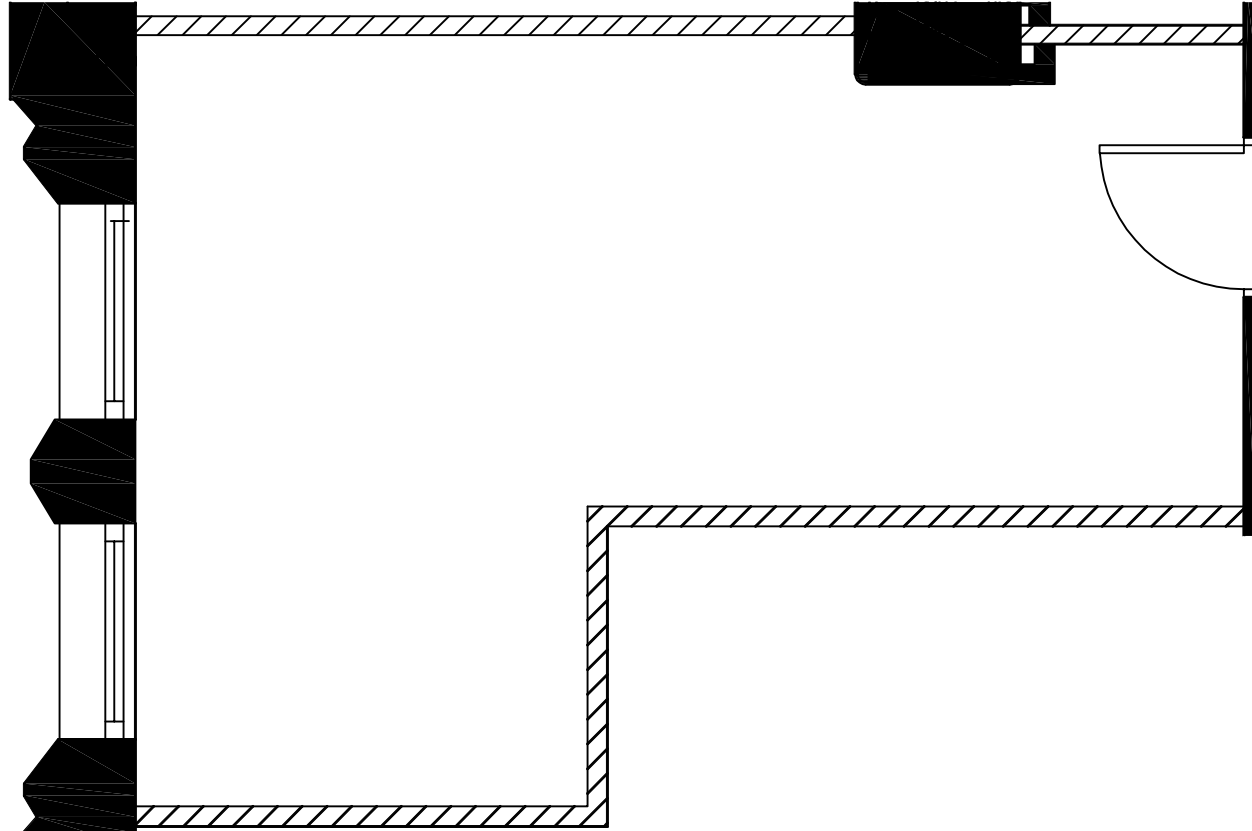
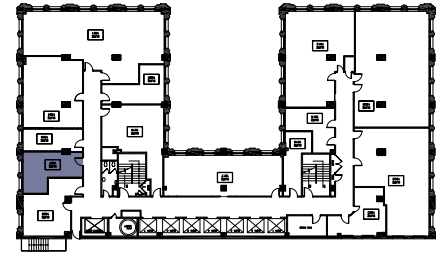

## SUITE 1827

327 RSF

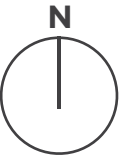

**CANDICE WELLS**

Leasing Agent  
312.884.5452 | [cwells@marcrealty.com](mailto:cwells@marcrealty.com)

55 E Jackson Blvd, Suite 500  
Chicago, IL 60604



Exceptional Value  
Remarkable Locations

# 30

NORTH MICHIGAN  
AVENUE

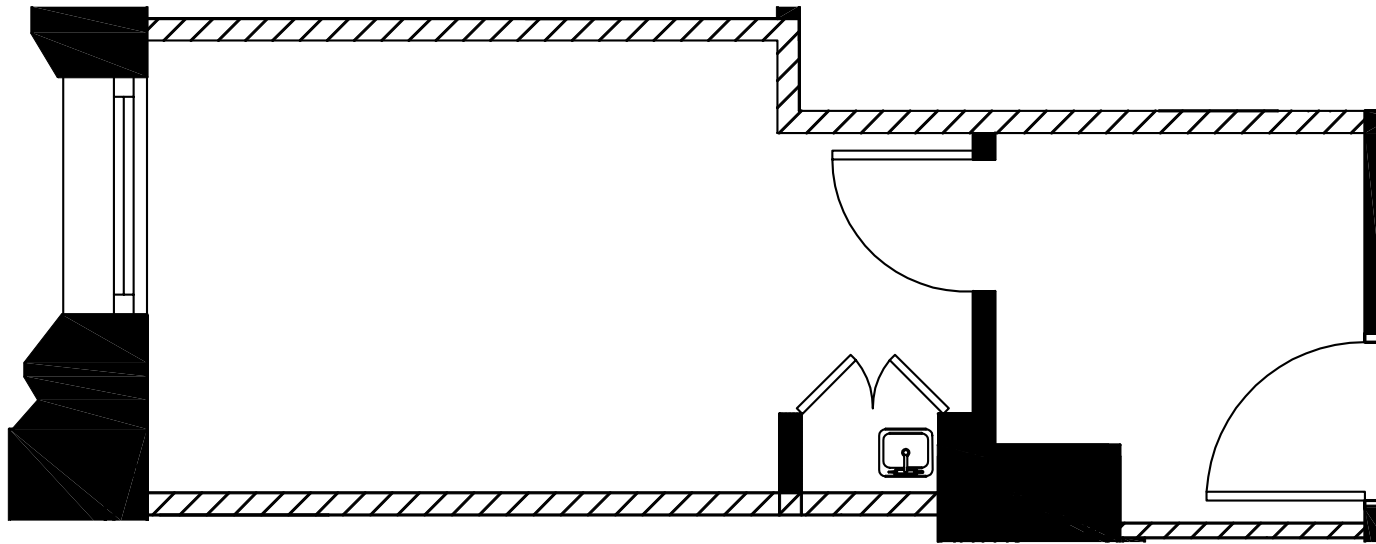
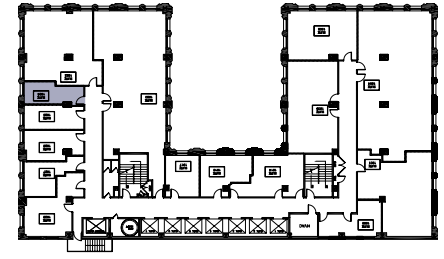

## SUITE 1924

260 RSF

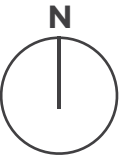

**CANDICE WELLS**

Leasing Agent  
312.884.5452 | [cwells@marcrealty.com](mailto:cwells@marcrealty.com)

55 E Jackson Blvd, Suite 500  
Chicago, IL 60604



Exceptional Value  
Remarkable Locations

# 30

NORTH MICHIGAN  
AVENUE

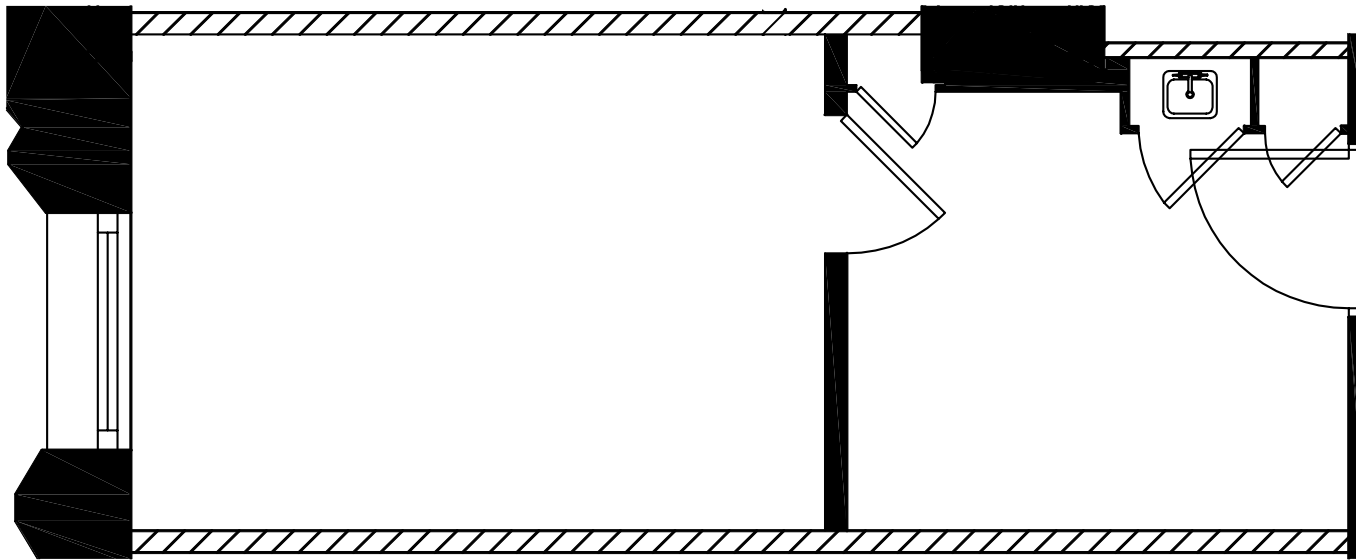
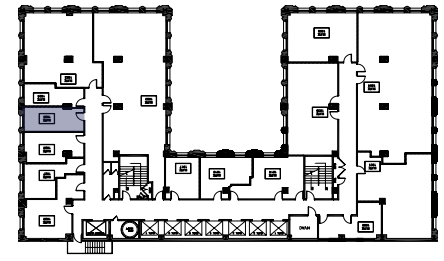

## SUITE 1925

263 RSF

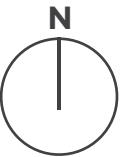

**CANDICE WELLS**

Leasing Agent  
312.884.5452 | [cwells@marcrealty.com](mailto:cwells@marcrealty.com)

55 E Jackson Blvd, Suite 500  
Chicago, IL 60604



Exceptional Value  
Remarkable Locations

# 30

NORTH MICHIGAN  
AVENUE

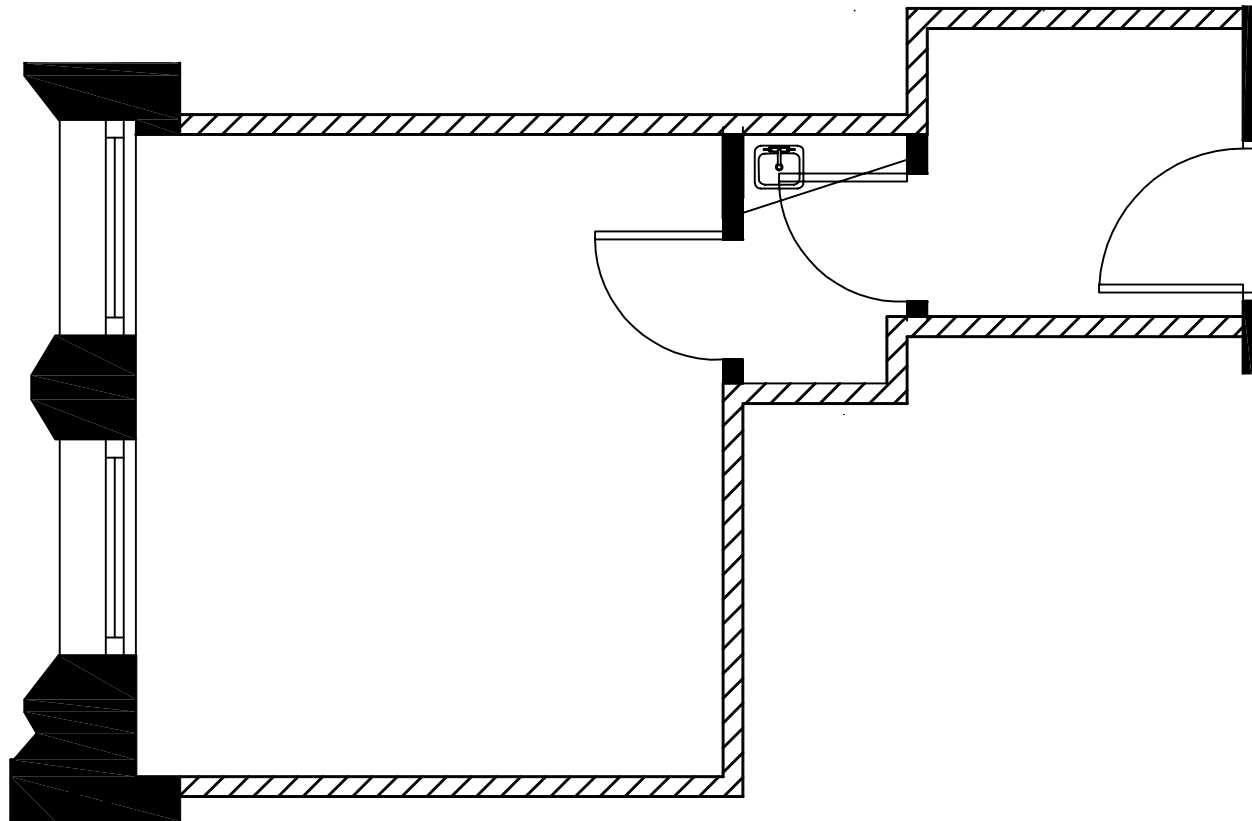
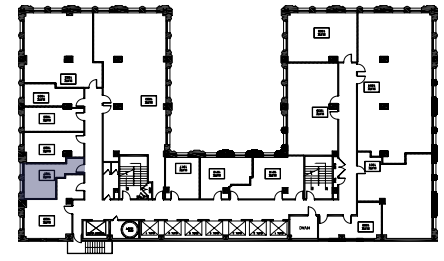

## SUITE 1927

277 RSF

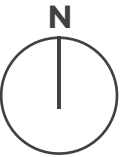

**CANDICE WELLS**

Leasing Agent  
312.884.5452 | [cwells@marcrealty.com](mailto:cwells@marcrealty.com)

55 E Jackson Blvd, Suite 500  
Chicago, IL 60604



Exceptional Value  
Remarkable Locations

# 30

NORTH MICHIGAN  
AVENUE

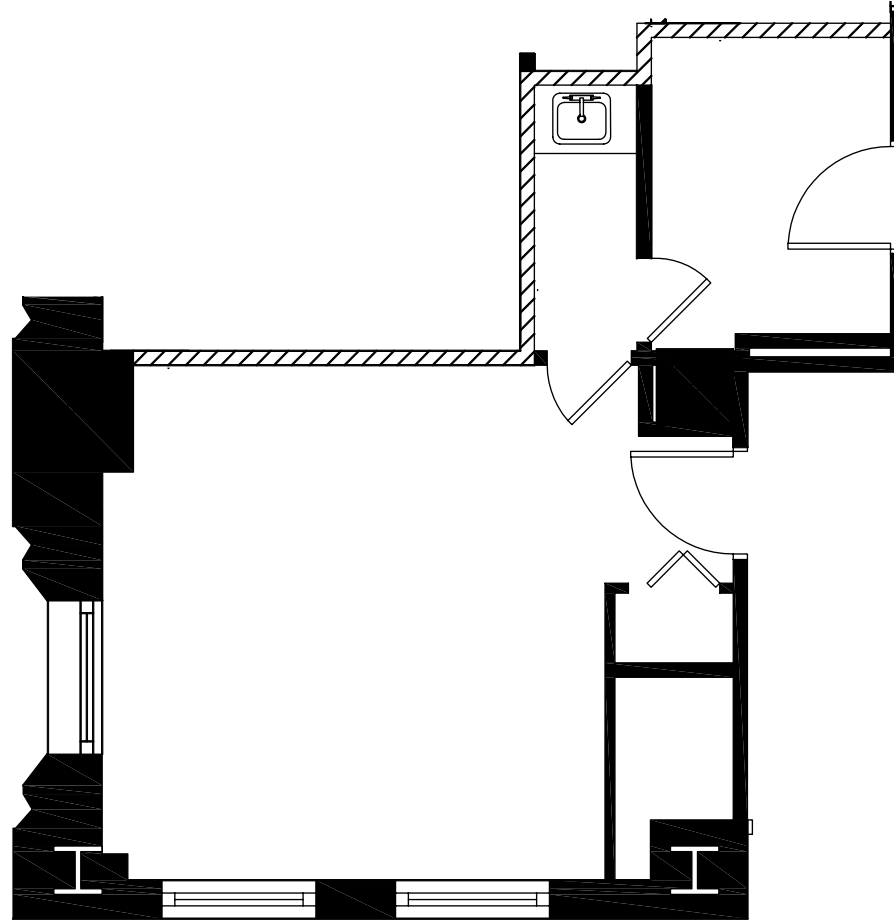
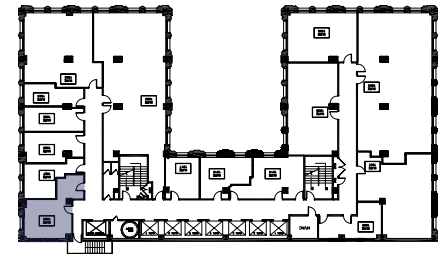

## SUITE 1928

400 RSF

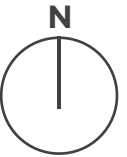

**CANDICE WELLS**

Leasing Agent  
312.884.5452 | [cwells@marcrealty.com](mailto:cwells@marcrealty.com)

55 E Jackson Blvd, Suite 500  
Chicago, IL 60604



Exceptional Value  
Remarkable Locations

# 30

NORTH MICHIGAN  
AVENUE

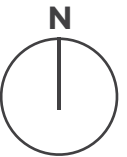
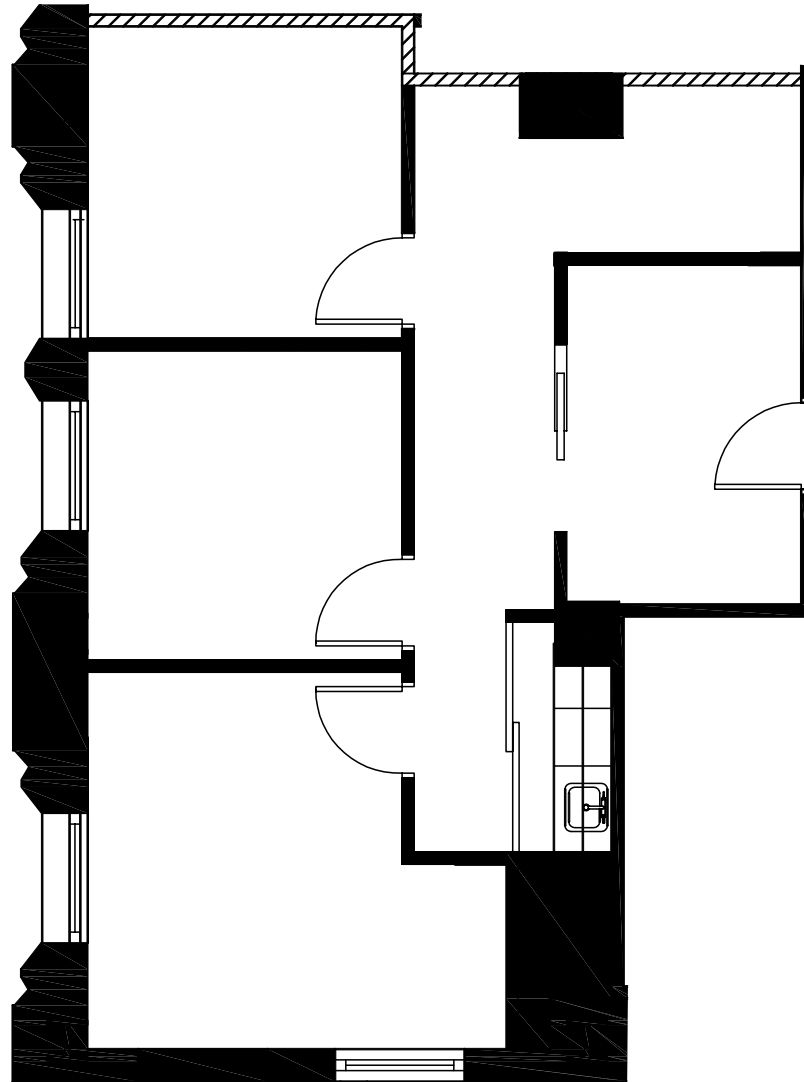
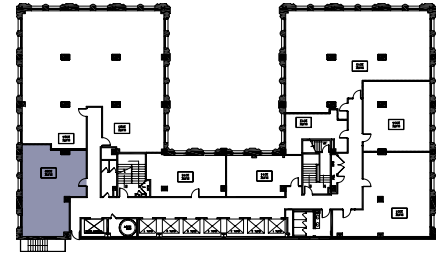

## SUITE 2029

956 RSF

**CANDICE WELLS**

Leasing Agent  
312.884.5452 | [cwells@marcrealty.com](mailto:cwells@marcrealty.com)

55 E Jackson Blvd, Suite 500  
Chicago, IL 60604



Exceptional Value  
Remarkable Locations

# 30

NORTH MICHIGAN  
AVENUE

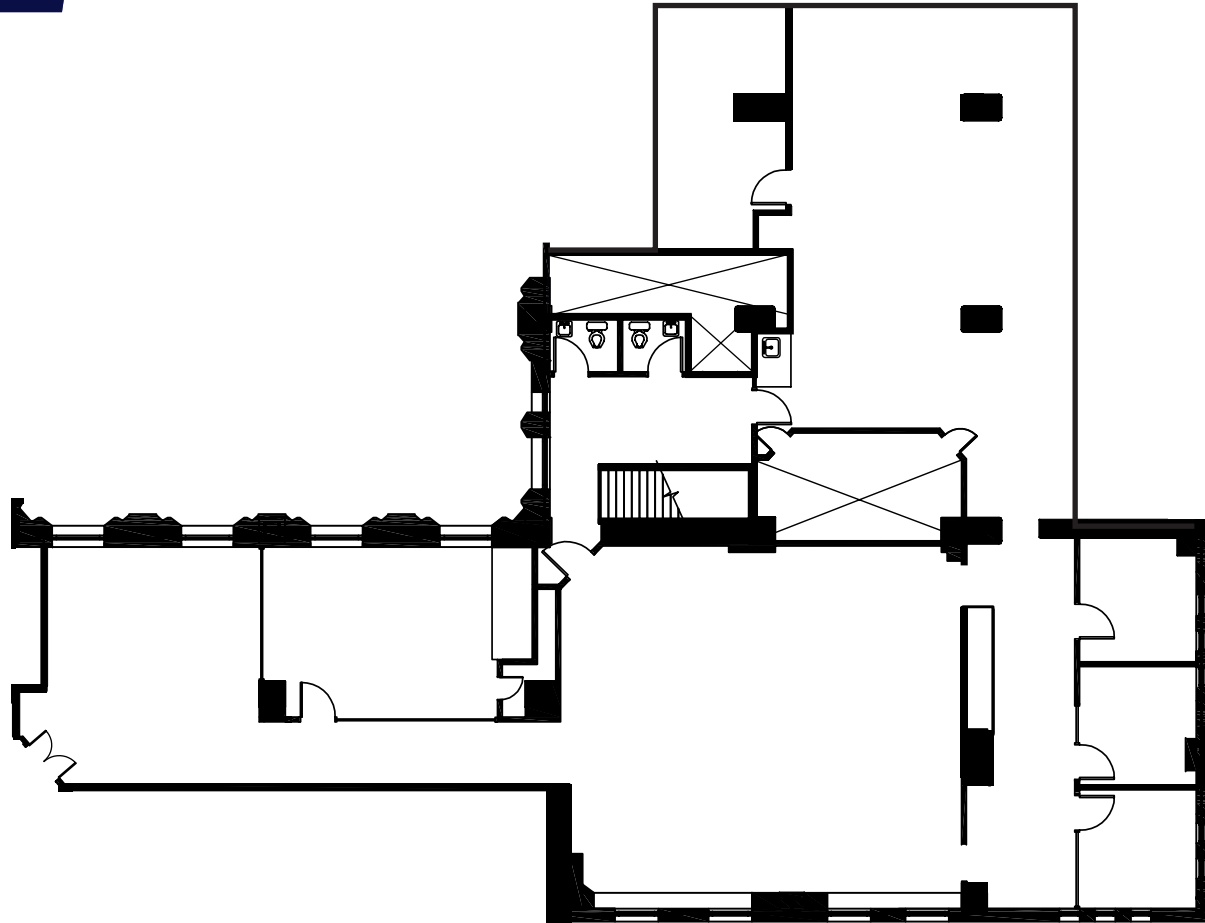
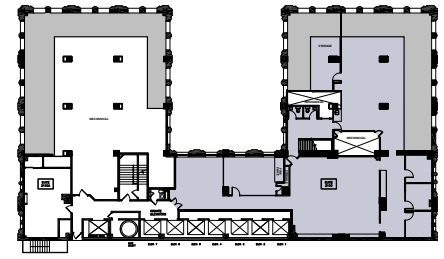

## SUITE 2100

5,007 RSF

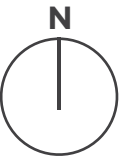

**CANDICE WELLS**

Leasing Agent  
312.884.5452 | [cwells@marcrealty.com](mailto:cwells@marcrealty.com)

55 E Jackson Blvd, Suite 500  
Chicago, IL 60604



Exceptional Value  
Remarkable Locations



# 30

NORTH MICHIGAN  
AVENUE

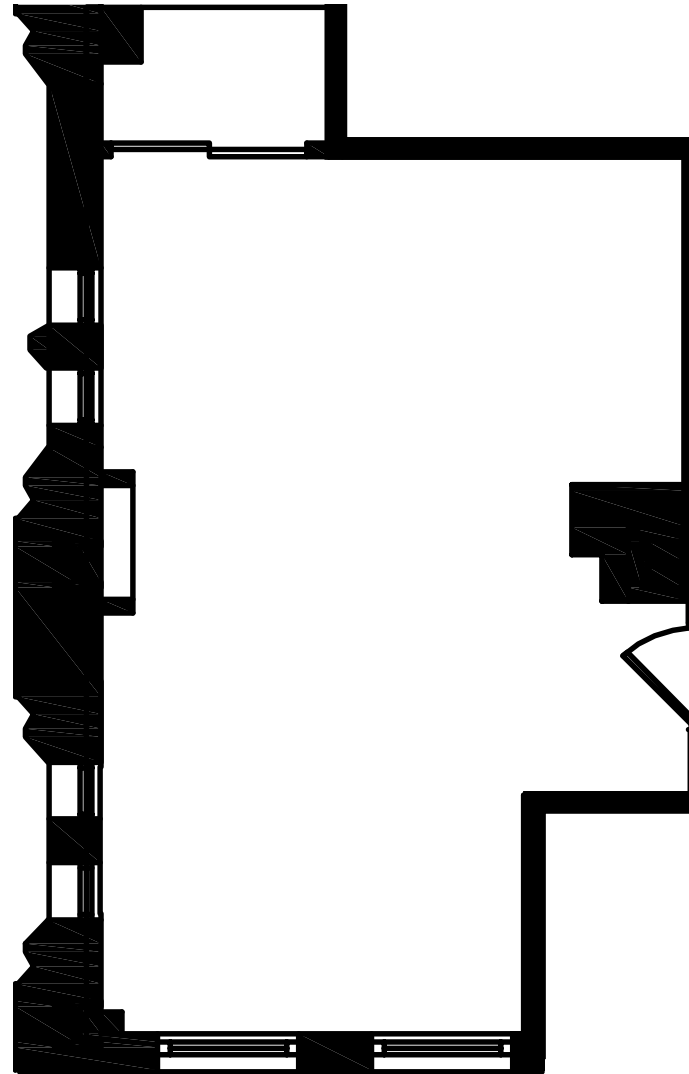
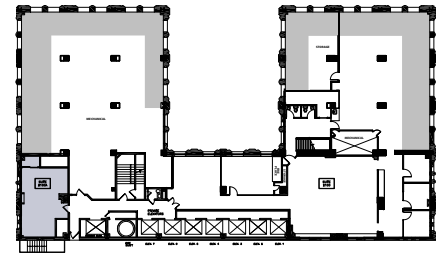

**SUITE 2110**  
**582 RSF**

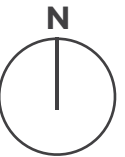

**CANDICE WELLS**

Leasing Agent  
312.884.5452 | [cwells@marcrealty.com](mailto:cwells@marcrealty.com)

55 E Jackson Blvd, Suite 500  
Chicago, IL 60604

**MR**  
MARC REALTY

Exceptional Value  
Remarkable Locations

# THE BEST LOCATED BUILDINGS

---

# CHICAGO

---

Striving to deliver the highest level of service within all aspects of our business. We pride ourselves in having a strong local knowledge of the real estate market with an equally strong understanding of our tenant's business needs. This allows us to better serve our individual clients by matching up their unique requirements with the best real estate decisions.



**MORE SPACES AVAILABLE  
AT MARCREALTY.COM**

**CANDICE WELLS**

Leasing Agent  
312.884.5452 | [cwells@marcrealty.com](mailto:cwells@marcrealty.com)

55 E Jackson Blvd, Suite 500  
Chicago, IL 60604



Exceptional Value  
Remarkable Locations